



M.S.KENNEDY CORP.

6W
DC-DC
CONVERTERS

DHC2800S
SERIES

4707 Dey Road Liverpool, N.Y. 13088

(315) 701-6751

FEATURES:

- 70% Typical Efficiency
- All Ceramic Capacitors
- Surface Mount Magnetics
- Withstands 5000G
- MIL STD 461C CE03 (With EFJ2803 Filter)
- 80 Volt Input Transient Tolerant
- No Derating - -55°C to $+125^{\circ}\text{C}$
- Wide Supply Range - 10V to 50V
- High Isolation - 500V
- High Power Density - $17\text{W}/\text{in}^3$
- Output Voltage Adjustment - Standard
- Remote Shutdown
- Operates to 11V Input at 5W
- Available with 3.3V or 5V Outputs
- See DAC2800s Series for 12V and 15V Versions
- Available to DSCC SMD 5962-94629 and 5962-93092

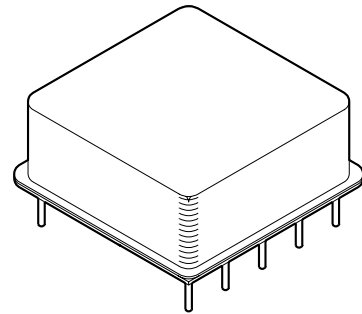
MIL-PRF-38534 CERTIFIED**DESCRIPTION:**

The DHC2800S series of DC-DC converters provides the ruggedness, reliability and features required to meet the advanced design challenges of today's hi-rel market. The use of advanced substrate and reflow soldering techniques during construction results in a rugged, cost-effective and completely solderable package.

DHC2800S hybrid converter series utilizes all ceramic capacitors and surface mount magnetics to provide reliable operation at all operating temperatures while surviving very high G forces.

DHC2800S standard features include output fault monitoring and/or turn on voltage point programming via the shutdown pin. All three functions may be implemented simultaneously with a minimum of external components. An output voltage adjustment/load compensation pin is also standard.

Fault tolerant design protects these converters from most external circuit faults. The output and output adjust pins will withstand $+35\text{V}$ while the shutdown pin will withstand $+50\text{V}$ protecting the converters from a variety of system or board faults i.e. solder bridges, etc. Unique load fault protection circuitry allows this converter to pull up loads having difficult static load line characteristics and allows short term load excursions significantly beyond ratings in most applications.

A transformer isolated forward converter topology operating at a switching frequency of 400kHz allows operation over a wide input voltage range. Internal filtering of both input and output eliminates the need for external capacitors in many applications.

The 8-pin DIP package is hermetically sealed and isolated from the internal circuits. Heat sinking is recommended for full power operation at elevated ambient temperatures.

EQUIVALENT SCHEMATIC

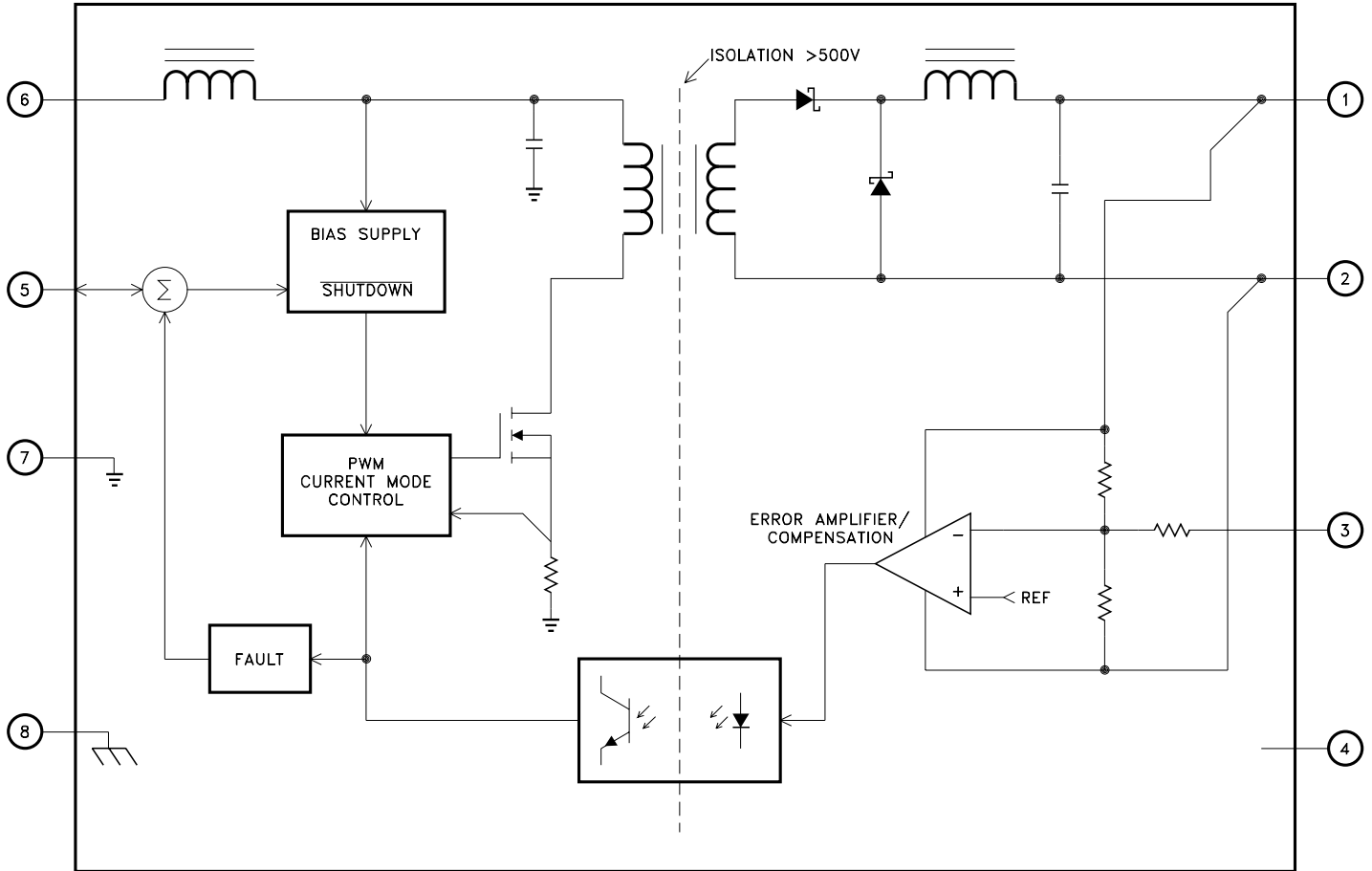

TYPICAL APPLICATIONS

- Isolated Step Down Power Supply
- Microprocessor Power Source
- Low Voltage Subsystem Power Source

PIN-OUT INFORMATION

1	+ Output	8	Case
2	-Output		
3	Adjust/Comp	7	-Input
4	NC		
5	Shutdown Plus	6	+Input

ABSOLUTE MAXIMUM RATINGS ^①

V_{IN}	Input Voltage (pin 7 to pin 6)	+50V
V_{INT}	Input Transient (pin 7 to pin 6 @ 50mS)	80V
I_{OUT}	Output Current	
	DHC2803S	2.0A
	DHC2805S	1.5A
T_C	Case Temperature Range	
	DHC2800S H/E	-55°C to +125°C
	DHC2800S	-40°C to +85°C

T_{ST}	Storage Temperature Range	-65°C to +150°C
T_{LD}	Lead Temperature Range (10 Seconds)	300°C
P_D	Power Dissipation	See Efficiency Curve
T_J	Junction Temperature	150°C
θ_{JC}	Thermal Resistance (Switches)	6.5°C/W

NOTE:

- ① Continuous operation at or above absolute maximum ratings may adversely affect the performance and/or life cycle.

ELECTRICAL SPECIFICATIONS

DHC2803S

Parameter ⑧	Test Conditions ①	Group A Subgroup	DHC2803S H/E			DHC2803S			Units
			Min.	Typ.	Max.	Min.	Typ.	Max.	
Output Voltage		1	3.20	3.30	3.40	3.18	3.30	3.42	VDC
		2,3	3.15	-	3.45	-	-	-	VDC
Output Current ②	12V ≤ VIN ≤ 50V	1	152	-	1520	152	-	1520	mA
		2,3	152	-	1520	-	-	-	mA
	16V ≤ VIN ≤ 50V	1	152	-	1820	152	-	1820	mA
		2,3	152	-	1820	-	-	-	mA
Output Voltage Ripple	BW = 10KHz to 2MHz	1	-	85	190	-	85	190	mVp-p
		2,3	-	-	475	-	-	-	mVp-p
Input Current Ripple ②	BW = 10KHz to 2MHz	1	-	165	200	-	165	225	mA _{p-p}
		2,3	-	-	200	-	-	-	mA _{p-p}
Line Regulation	VIN = 16V to 40V	1	-	±6	±15	-	±6	±20	mV
		2,3	-	-	±50	-	-	-	mV
Load Regulation	VIN = 16V, 28V and 40V IOUT = 0A, 0.9A and 1.8A	1	-	±20	±35	-	±20	±45	mV
		2,3	-	-	±50	-	-	-	mV
Efficiency		1	61	66	-	61	66	-	%
		2,3	58	-	-	-	-	-	%
Step Load Response	IOUT = 0.9A to/from 1.8A Transition Time = 30μS	4	-	±430	±600	-	±430	±650	mV
		5,6	-	-	±850	-	-	-	mV
Step Load Recovery	IOUT = 0.9A to/from 1.8A Transition Time = 30μS	4	-	85	300	-	85	300	μS
		5,6	-	-	300	-	-	-	μS
Step Line Response ②	VIN = 16V to/from 40V Transition Time = 30μS	4	-	±190	±500	-	±190	±500	mV
		5,6	-	-	±500	-	-	-	mV
Step Line Recovery ②	VIN = 16V to/from 40V Transition Time = 30μS	4	-	120	500	-	120	500	μS
		5,6	-	-	500	-	-	-	μS
Start Up Overshoot		4	-	0	200	-	0	200	mV
		5,6	-	0	200	-	-	-	mV
Start Up Delay		4	-	30	50	-	30	50	mS
		5,6	-	-	50	-	-	-	mS
Shutdown Delay ②		4	-	220	500	-	220	500	μS
		5,6	-	-	500	-	-	-	μS
Shutdown Recovery ②		-	-	60	-	60	-	mS	
Input Voltage Range ②	POUT = 6W MAX.	1,2,3	12	-	50	12	-	50	V
	POUT = 5W MAX.	1,2,3	11	-	50	11	-	50	V
	POUT = 2.5W MAX.	1,2,3	10	-	50	10	-	50	V
Quiescent Current	Enabled, IOUT = 0mA	1,2,3	-	35	40	-	35	45	mA
	Disabled IOUT = 0mA	1,2,3	-	2	5	-	2	5	mA
Capacitive Load ②	No Effect on DC Performance	1,2,3	-	-	300	-	-	300	μF
Isolation	Input to output or any pin to case @ 500V	1	100	-	-	100	-	-	MΩ
Short Circuit Current Limit ⑦		1	2.3	2.8	3.6	2.3	2.8	3.6	A
Switching Frequency		4	375	400	425	350	400	450	KHz
VOUT Adjustment Range	RPOT = 50KΩ	1	±10	-	-	±10	-	-	%

NOTES:

- ① + VIN = 28V, IOUT = 1.8A for DHC2803S, IOUT = 1.0A for DHC2805S, TA = TC = 25°C unless otherwise specified.
- ② Guaranteed by design but not tested. Typical parameters are representative of actual device performance but are for reference only.
- ③ Industrial grade and "E" suffix devices shall be tested to subgroups 1 and 4 unless otherwise specified.
- ④ Military grade devices ("H" suffix) shall be 100% tested to subgroups 1, 2, 3 and 4.
- ⑤ Subgroups 5 and 6 testing available upon request.
- ⑥ Subgroup 1, 4 TA = TC = +25°C
2, 5 TA = TC = +125°C
3, 6 TA = TC = -55°C
- ⑦ Device has internal shutdown feature that pulses the output with a low duty cycle during faults.
- ⑧ Refer to DSCC SMD for electrical specifications for devices purchased as such.

ELECTRICAL SPECIFICATIONS

DHC2805S

Parameter ⑧	Test Conditions ①	Group A Subgroup	DHC2805S H/E			DHC2805S			Units
			Min.	Typ.	Max.	Min.	Typ.	Max.	
Output Voltage		1	4.95	5.00	5.05	4.90	5.00	5.10	VDC
		2,3	4.80	-	5.20	-	-	-	VDC
Output Current ②	12V ≤ VIN ≤ 50V	1	120	-	1200	120	-	1200	mA
		2,3	120	-	1200	-	-	-	mA
	16V ≤ VIN ≤ 50V	1	120	-	1500	120	-	1500	mA
		2,3	120	-	1500	-	-	-	mA
Output Voltage Ripple	BW = 10KHz to 2MHz	1	-	75	190	-	75	190	mVp-p
		2,3	-	-	475	-	-	-	mVp-p
Input Current Ripple ②	BW = 10KHz to 2MHz	1	-	100	200	-	100	225	mAp-p
		2,3	-	-	200	-	-	-	mAp-p
Line Regulation	VIN = 16V to 40V	1	-	±6	±15	-	±6	±20	mV
		2,3	-	-	±50	-	-	-	mV
Load Regulation	VIN = 16V, 28V and 40V IOUT = 0A, 0.5A and 1A	1	-	±10	±25	-	±10	±30	mV
		2,3	-	-	±50	-	-	-	mV
Efficiency		1	64	70	-	64	70	-	%
		2,3	62	-	-	-	-	-	%
Step Load Response	IOUT = 500mA to/from 1000mA Transition Time = 30μS	4	-	±300	±500	-	±300	±500	mV
		5,6	-	-	±750	-	-	-	mV
Step Load Recovery	IOUT = 500mA to/from 1000mA Transition Time = 30μS	4	-	90	300	-	90	300	μS
		5,6	-	-	300	-	-	-	μS
Step Line Response ②	VIN = 16V to/from 40V Transition Time = 30μS	4	-	±160	±500	-	±160	±500	mV
		5,6	-	-	±500	-	-	-	mV
Step Line Recovery ②	VIN = 16V to/from 40V Transition Time = 30μS	4	-	140	500	-	140	500	μS
		5,6	-	-	500	-	-	-	μS
Start Up Overshoot	IOUT = 1A	4	-	0	200	-	0	200	mV
		5,6	-	0	200	-	-	-	mV
Start Up Delay	IOUT = 0A and 1A	4	-	30	50	-	30	50	mS
		5,6	-	-	50	-	-	-	mS
Shutdown Delay ②		4	-	220	500	-	220	500	μS
		5,6	-	-	500	-	-	-	μS
Shutdown Recovery ②		-	-	60	-	60	-	mS	
Input Voltage Range ②	POUT = 6W MAX.	1,2,3	12	-	50	12	-	50	V
	POUT = 5W MAX.	1,2,3	11	-	50	11	-	50	V
	POUT = 2.5W MAX.	1,2,3	10	-	50	10	-	50	V
Quiescent Current	Enabled, IOUT = 0mA	1,2,3	-	35	40	-	35	45	mA
	Disabled IOUT = 0mA	1,2,3	-	2	5	-	2	5	mA
Capacitive Load ②	No Effect on DC Performance	1,2,3	-	-	300	-	-	300	μF
Isolation	Input to output or any pin to case @ 500V	1	100	-	-	100	-	-	MΩ
Short Circuit Current Limit ⑦		1	1.6	1.9	2.2	1.5	1.9	2.3	A
Switching Frequency		4	375	400	425	350	400	450	KHz
VOUT Adjustment Range	RPOT = 50KΩ	1	±10	-	-	±10	-	-	%

NOTES:

- ① +VIN = 28V, IOUT = 1.8A for DHC2803S, IOUT = 1.0A for DHC2805S, TA = TC = 25°C unless otherwise specified.
- ② Guaranteed by design but not tested. Typical parameters are representative of actual device performance but are for reference only.
- ③ Industrial grade and "E" suffix devices shall be tested to subgroups 1 and 4 unless otherwise specified.
- ④ Military grade devices ("H" suffix) shall be 100% tested to subgroups 1, 2, 3 and 4.
- ⑤ Subgroups 5 and 6 testing available upon request.
- ⑥ Subgroup 1, 4 TA = TC = +25°C
2, 5 TA = TC = +125°C
3, 6 TA = TC = -55°C
- ⑦ Device has internal shutdown feature that pulses the output with a low duty cycle during faults.
- ⑧ Refer to DSCC SMD for electrical specifications for devices purchased as such.

APPLICATION NOTES

POWER SUPPLIES

The output voltage of the DHC2800S may be adjusted from 90% to 110% of nominal value by the use of a 50K Ω potentiometer as shown. Adjustment beyond this range is possible however certain characteristics of the converter such as but not limited to input voltage range, efficiency, ripple and temperature performance will change. Characterization by the user is recommended in such applications.

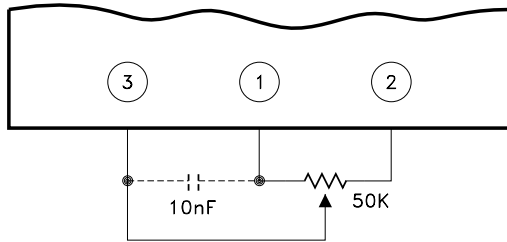

Adjust/comp (pin 3) may be driven by external circuitry referenced to pin 2 (-output) if desired. Grounding pin 3 causes voltage to increase (25% typically) while driving pin 3 above 1.3V causes output voltage to decrease. Pin 3 may be driven through 10K Ω or more if connection of the comp function is also required.

The comp function of pin 3 allows capacitive loads as large as 1000 μ F to be accommodated on the DHC2805S without loss of stability. This feature may be utilized by connecting a 10nF capacitor between pins 3 and 1. This is generally recommended when low ESR load capacitances of 100 μ F or greater are used.

SHUTDOWN PLUS

Pin 5 is used for remote shutdown, output fault detection, and/or setting the input voltage point at which the converter will turn on as shown in the typical application diagram. No connection to pin 5 is necessary for normal operation of the converter. Pin 5 is referenced to the -input (pin 7).

Shutdown may be implemented by simply connecting pin 5 to an open collector logic output or switch rated at 2.5mA, 25Vdc or higher.

Input voltage turn on point is programmed with a single resistor from pin 5 to 7. An input turn on/off hysteresis (typically 3.5% of V_{in}) will be observed. This should be considered when making or verifying set point adjustment. The value of the setpoint resistor may be determined by the following:

$$R = \frac{210 \cdot 10^3}{E_{TO} - 9.5} \quad (\pm 10\% \text{ accuracy at } 25^\circ\text{C})$$

Set point temperature coefficient is typically +400ppm/ $^\circ$ C.

Output fault monitoring is accomplished by observing pin 5 with a high impedance monitoring circuit. Pin 5 voltage drops from over 10V to below 1V when a load fault causes the converters fault protection circuitry to activate. It will remain low for at least 100mS and return high. If the load fault is still present pin 5 will return low and the cycle will repeat. A resistor >400K Ω from pin 5 to 7 provides pull down for pin 5 if there is no input setpoint programming resistor already in place.

LOAD FAULT RESPONSE

The DHC2800S series of dc-dc converters share load fault philosophies. Load fault conditions include short-circuit and severe overload conditions. The DHC2800S converter series responds to load faults by turning off all power conversion circuits for 250mS and then attempting to restart for 10mS (typical). The net "on" duty factor during a fault is very low resulting in low converter dissipation and immunity from overheating at 125 $^\circ$ C. Current beyond rated can flow into the load at startup time. This allows the converter to bring up capacitive and other difficult load types more reliably than competing converters.

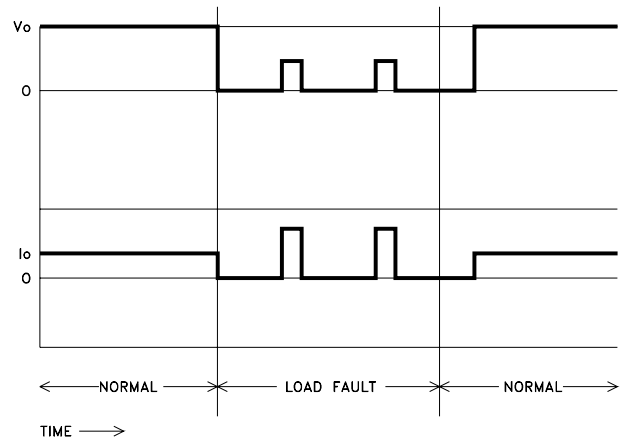

TYPICAL APPLICATION CIRCUIT

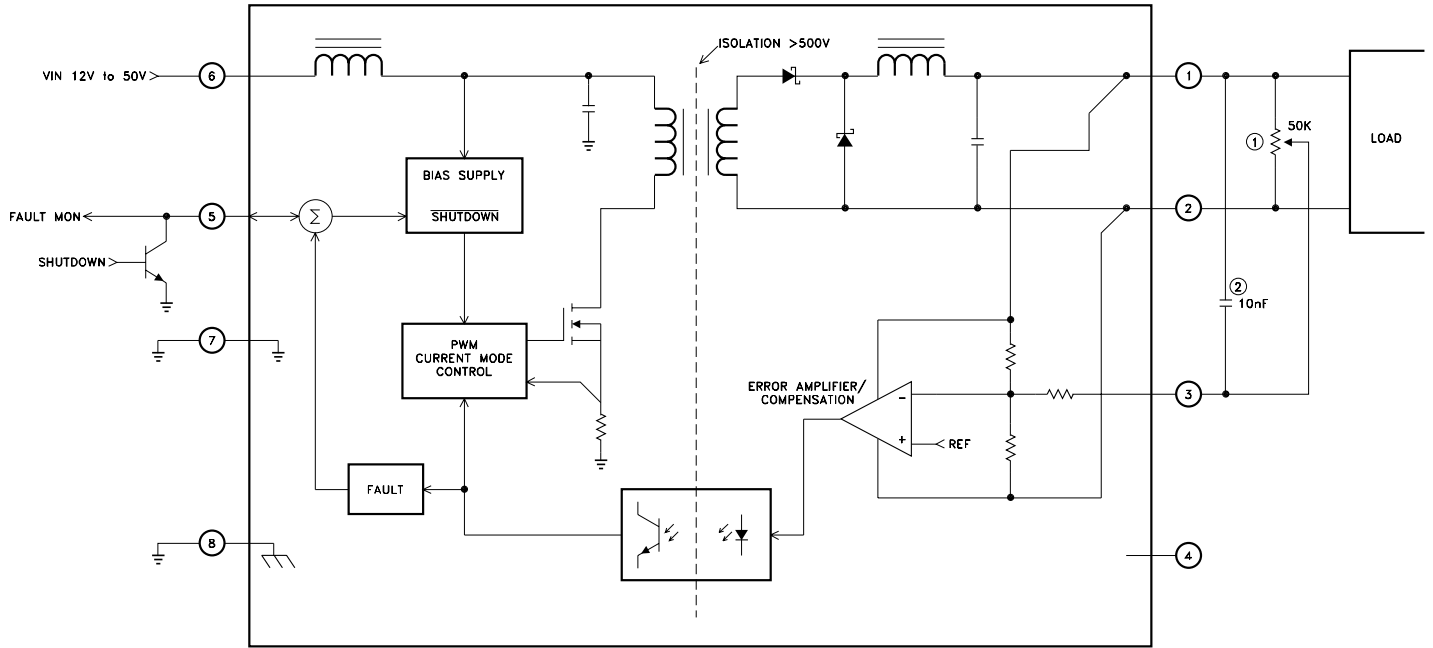

NOTES:

1. OPTIONAL OUTPUT ADJUSTMENT RESISTOR. SEE PARAGRAPH TITLED POWER SUPPLIES.
2. OPTIONAL COMPENSATION CAPACITOR. SEE PARAGRAPH TITLED POWER SUPPLIES.

TYPICAL PERFORMANCE CURVES

DHC2803S

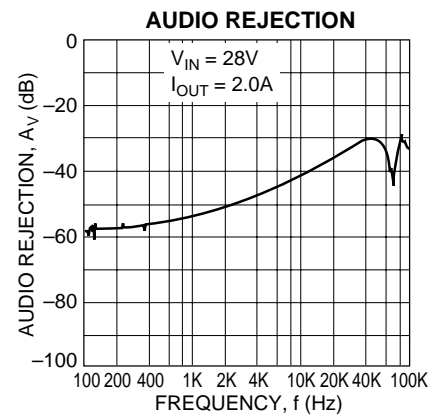
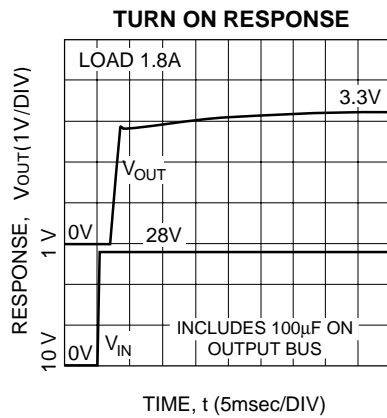
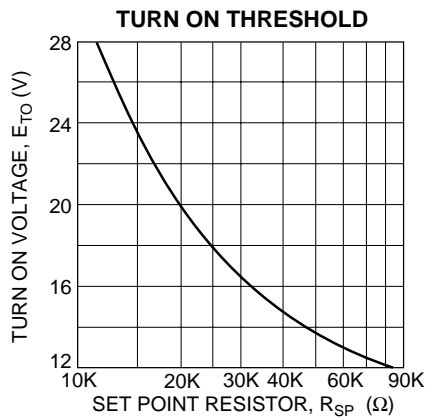
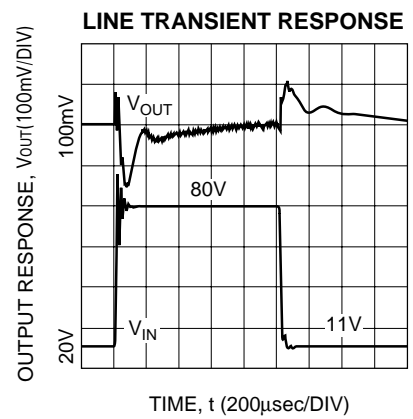
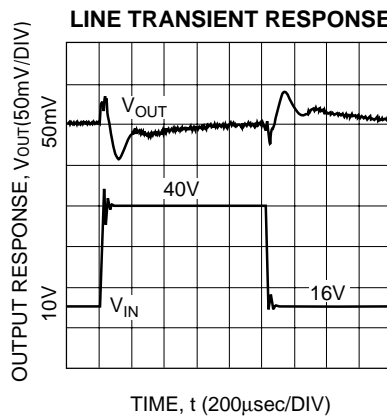
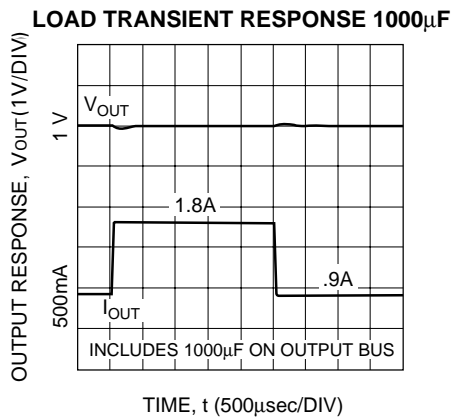
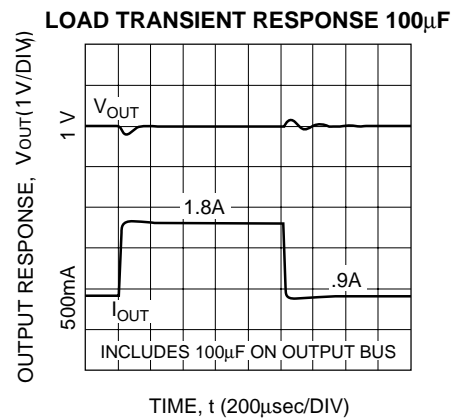
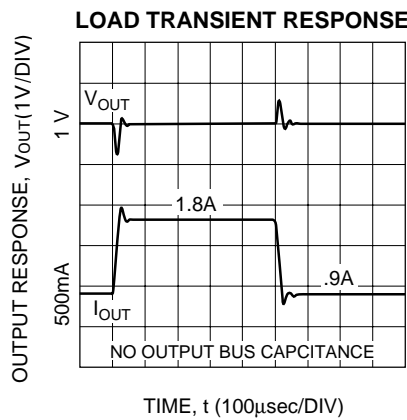
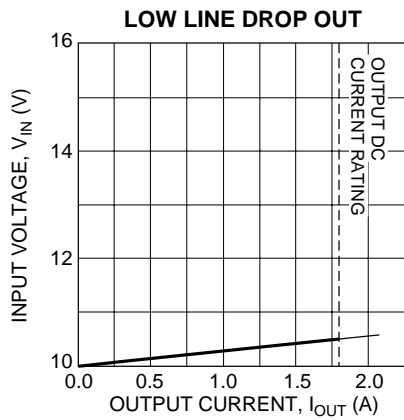
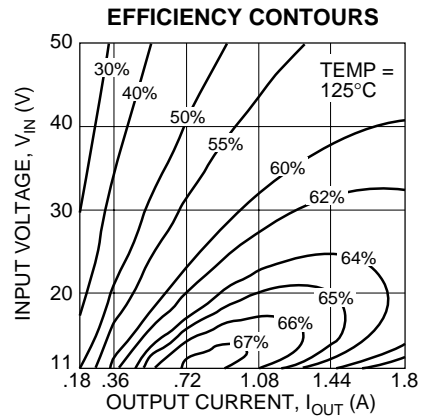
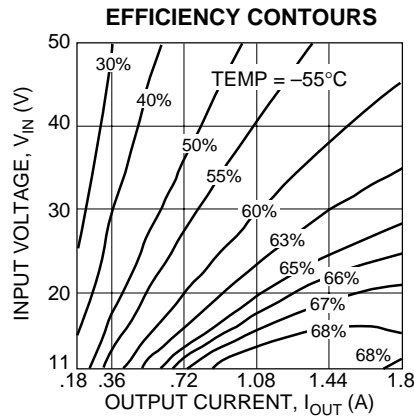
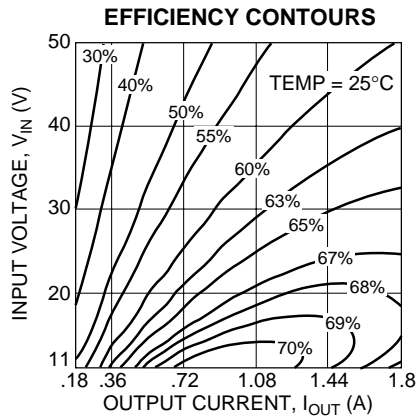

TYPICAL PERFORMANCE CURVES

DHC2805S

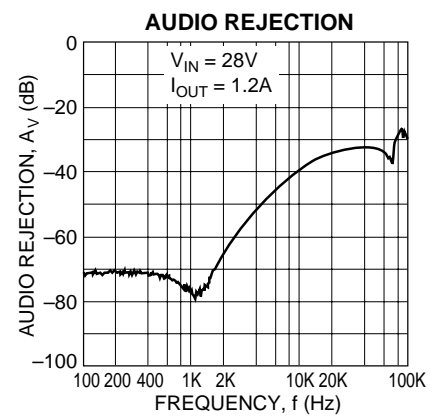
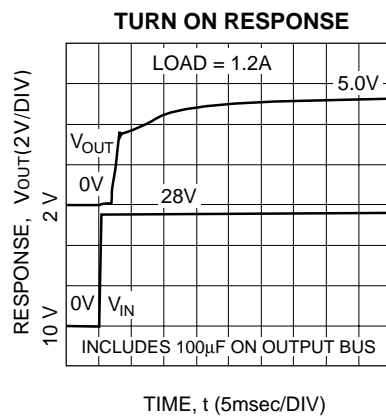
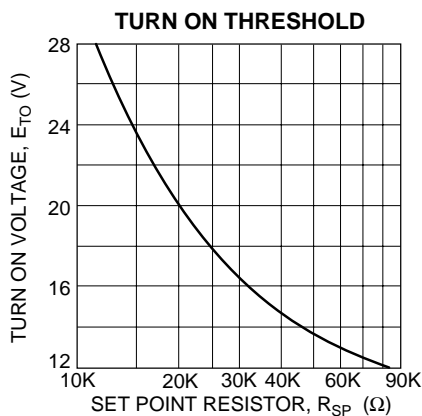
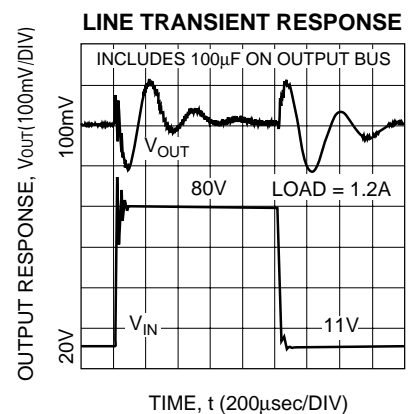
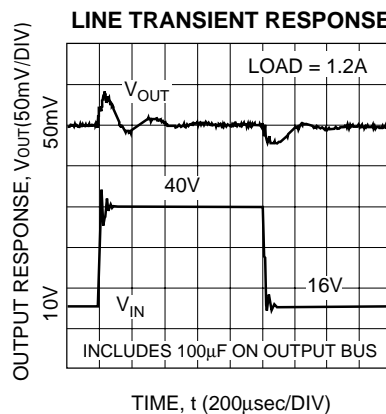
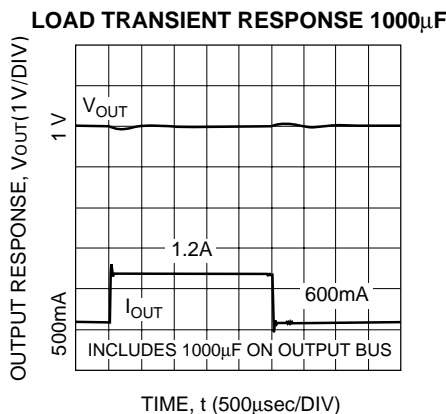
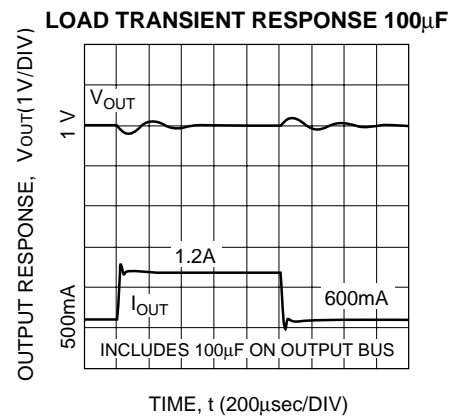
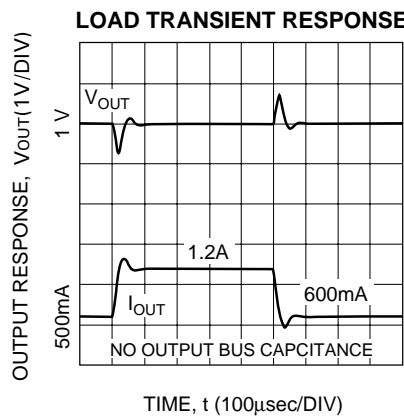
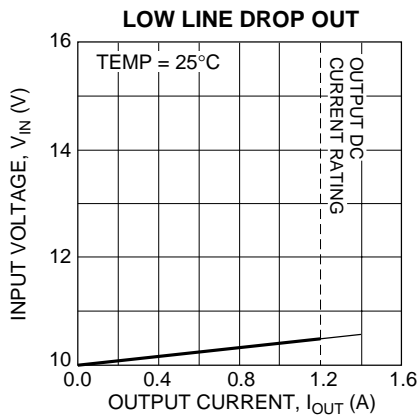
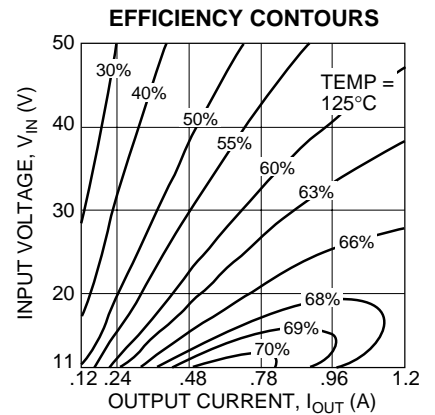
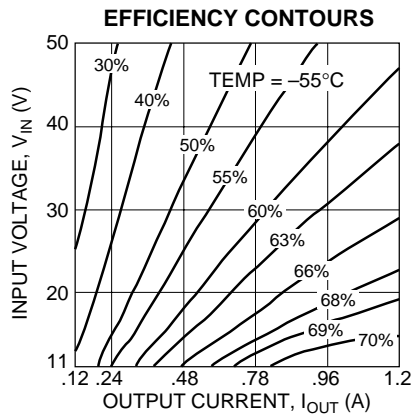
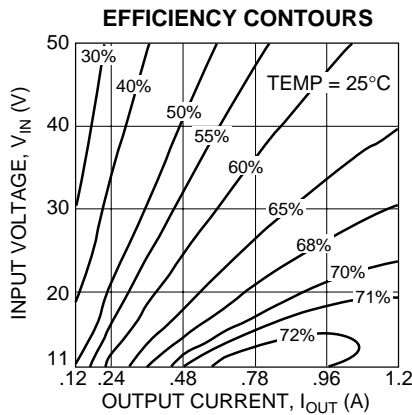

MECHANICAL SPECIFICATIONS

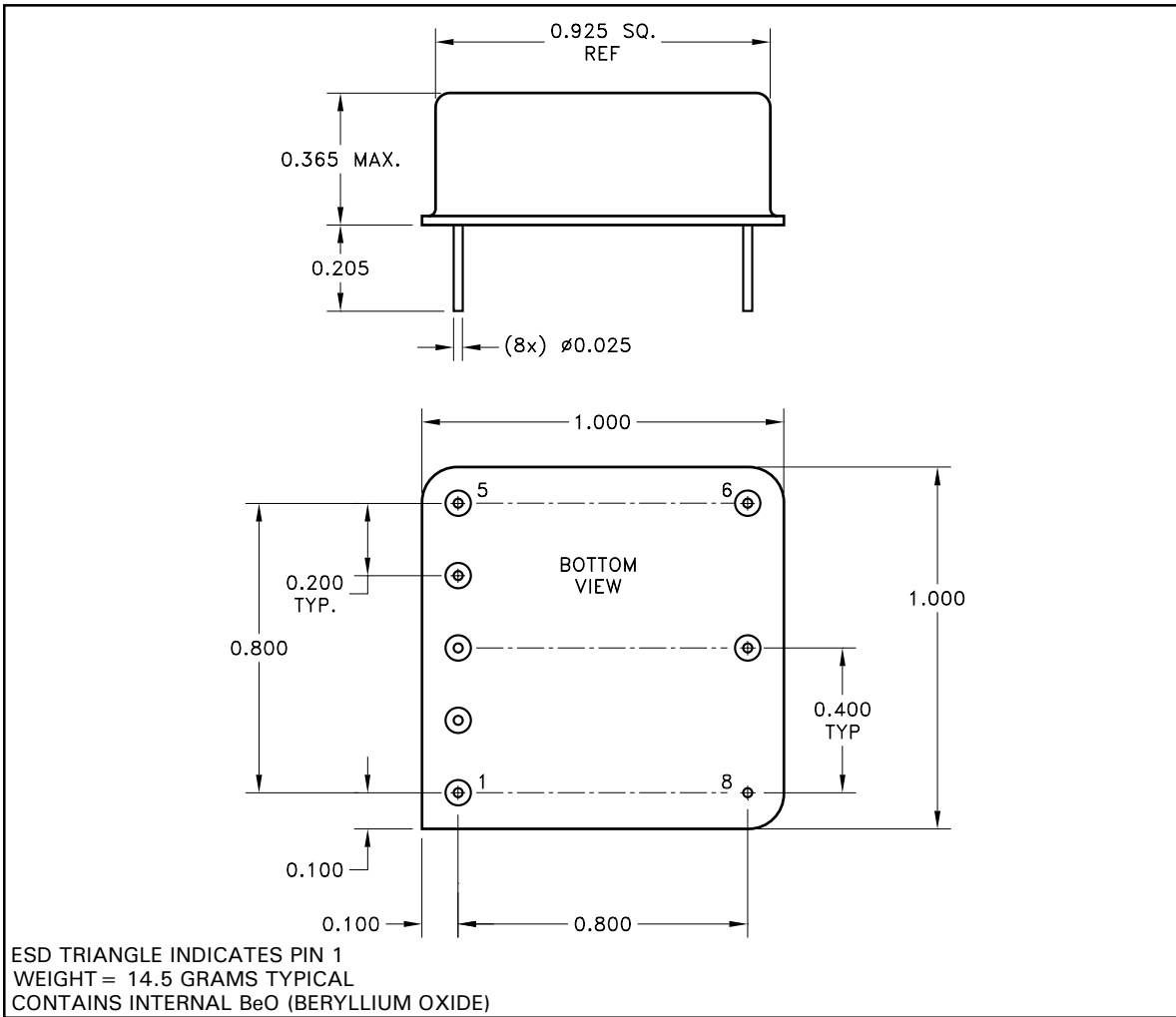

ALL DIMENSIONS ARE ± 0.010 INCHES UNLESS OTHERWISE LABELED

ORDERING INFORMATION

Part Number	Screening Level	Output Voltage
DHC2803S	Industrial	3.3V
DHC2803SE	Extended Reliability	
DHC2803SH	Mil-PRF-38534 Class H	
DHC2805S	Industrial	5.0V
DHC2805SE	Extended Reliability	
DHC2805SH	Mil-PRF-38534 Class H	
5962-93092	DSCC-SMD for DHC2805S	
5962-94629	DSCC-SMD for DHC2805S	

M.S. Kennedy Corp.
 4707 Dey Road, Liverpool, New York 13088
 Phone (315) 701-6751
 FAX (315) 701-6572
www.mskennedy.com

The information contained herein is believed to be accurate at the time of printing. MSK reserves the right to make changes to its products or specifications without notice, however, and assumes no liability for the use of its products. Please visit our website for the most recent revision of this datasheet.