



## **Voltage Regulators**

By Brent Erwin, MS Kennedy Corp.; Revised 9/19/2013

### **Introduction**

---

MS Kennedy offers a wide variety of voltage regulators for use in many different applications. Although each product line has its own benefits, there are many advantages that they all share. For instance, all of our voltage regulators are available in military hermetic packaging and may be screened to military or industrial specifications. Also, most regulators are available with various lead bend configurations for easy integration into many systems. In addition to lead bend configurations, various packaging is also available. Most packages offer isolated tabs for direct connection to heat sinks.

From an electrical standpoint, MS Kennedy voltage regulators offer low noise, providing clean outputs for your sensitive analog applications. As well as excellent electrical specifications, our voltage regulators also present exceptional thermal characteristics. Low  $\theta_{JC}$  values allow MSK to achieve high output currents and at the same time offer compact package configurations.

What follows is a breakdown of the specific advantages of the various voltage regulator lines. For more detailed information concerning any of the voltage regulators consult the MSK voltage regulator selection guide or each of the individual data sheets.

In addition to our standard linear voltage regulators, MS Kennedy also has a line of high efficiency step-down switching regulators. Advantages of these switching regulators include low quiescent current, user programmable current limit and “soft start”, and high efficiency that keeps the internal power dissipation low.

The MSK 5030's and 5040's are internally configured for an operating frequency of 300 KHz. The MSK 5030 series is available in either 2.5V, 3.3V, 5.0V or 7. Page of 0V versions, while the MSK 5040 series has preset voltages of 5.0V, 3.3V, 2.5V and 1.9V. All of the switching regulators are rated for up to 4 amps of output current.

These devices operate in three different modes that are dependent on how heavily the output is loaded. At low load levels, they function in a pulse skipping mode with discontinuous inductor current. As the load is increased to between 10% and 30% of the current threshold, the device will switch to a pulse skipping mode with continuous inductor current. If the output load is greater than 30% of the current threshold then the device will operate in a constant frequency PWM mode that provides continuous inductor current.

As was noted earlier, both lines of switching regulators have user programmable “soft start” and externally programmable current limit capabilities. These regulators

also offer the use of an enable pin for device start-up. The MSK 5030's are packaged in an 8 pin bathtub and the MSK 5040's are available in a 44 pin surface mount flat pack. For further information on additional features, as well as input/output capacitor selection, please refer to the factory data sheets for either the MSK 5030 series or the MSK 5040 series.

## **Summary of Regulator Specifications**

---

### *Linear Regulators*

#### **MSK 5000 Series**

1. Both positive and negative output voltages
2. Maximum output current = 3 amps for each regulator
3. Internally set output voltages to  $\pm 1\%$
4. Low dropout for both regulators (typically less than 1.2V)
5. Many output voltage combinations available (contact the factory)
6. Internal short circuit current limit

#### **MSK 5010 Series**

1. Fixed output voltages at 3.3V, 5.0V and 12.0V
2. Maximum output current = 10 amps
3. Internally set output voltages to  $\pm 1\%$
4. TTL level enable pin

#### **MSK 5012 Series**

1. Output voltage adjustable from 1.3V to 36V
2. Maximum output current = 10 amps
3. Low external component count to adjust output voltage

#### **MSK 5020 Series**

1. Fixed output voltage at 3.3V, 5.0V and 12.0V
2. Maximum output current = 20 amps
3. Internally set output voltages to  $\pm 1\%$
4. TTL level enable pin
5. Externally programmable current limit
6. Fault pin to monitor regulation dropout

#### **MSK 5021 Series**

1. Adjustable output voltage from 1.3V to 36V with two external resistors
2. Maximum output current = 20 amps
3. TTL level enable pin
4. Externally programmable current limit

5. Fault pin to monitor regulation dropout

### **MSK 5100 Series**

1. Fixed output voltages of 3.3V, 5.0V and 12.0V
2. Adjustable output version also available
3. Maximum output current = 1.5 amps
4. Extremely low dropout (typically 350 mV)
5. TTL level enable pin
6. Open collector error flag output
7. Extremely compact 10 pin SOIC with heat sink tab

### **MSK 5115 Series**

1. Fixed output voltages at 3.3V, 5.0V and 12.0V
2. Adjustable output version also available
3. Maximum output current = 1.5 amps
4. TTL level enable pin
5. Open collector error flag output available with the fixed voltage versions

### **MSK 5130 Series**

1. Fixed output voltages at 3.3V, 5.0V and 12.0V
2. Adjustable output version also available
3. Maximum output current = 3.0 amps
4. TTL level enable pin
5. Open collector error flag output available with the fixed voltage versions

### **MSK 5150 Series**

1. Fixed output voltages at 3.3V, 5.0V and 12.0V
2. Adjustable output version also available
3. Maximum output current = 5.0 amps
4. TTL level enable pin
5. Open collector error flag output available with the fixed voltage versions

### **MSK 5175 Series**

1. Fixed output voltages at 3.3V, 5.0V and 12.0V
2. Adjustable output version also available
3. Maximum output current = 7.5 amps
4. TTL level enable pin
5. Open collector error flag output available with the fixed voltage versions

### **MSK 5200 Series**

1. Both positive and negative output voltages
2. Maximum output current = 3 amps for each regulator

3. Internally set output voltages to  $\pm 1\%$
4. Ultra low dropout for both regulators (typically less than .65V)
5. Many output voltage combinations available (contact the factory)
6. Internal short circuit current limit.

### **MSK 5215 Series**

1. Fixed voltages at 2.5V, 3.3V, 5.0V and 12.0V
2. Internally set voltages to  $\pm 1\%$
3. Maximum output current = 1.5 amps
4. On board thermal shutdown
5. Hermetic surface mount package

### **MSK 5230 Series**

1. Fixed voltages at 2.5V, 3.3V, 5.0V and 12.0V
2. Internally set voltages to  $\pm 1\%$
3. Maximum output current = 3.0 amps
4. On board thermal shutdown
5. Hermetic surface mount package

### **MSK 5250 Series**

1. Fixed voltages at 2.5V, 3.3V, 5.0V and 12.0V
2. Internally set voltages to  $\pm 1\%$
3. Maximum output current = 5.0 amps
4. On board thermal shutdown
5. Hermetic surface mount package

### **MSK 5275 Series**

1. Fixed voltages at 2.5V, 3.3V, 5.0V and 12.0V
2. Internally set voltages to  $\pm 1\%$
3. Maximum output current = 7.5 amps
4. On board thermal shutdown
5. Hermetic surface mount package

### ***Switching Regulators***

#### **MSK 5030 Series**

1. Fixed output voltages of 3.3V and 5.0V
2. 96% efficiency
3. Maximum output current = 4 amps
4. User programmable current limit
5. User programmable “soft-start”
6. Enable function for user controlled start-up
7. Low total internal power dissipation

## **MSK 5040 Series**

1. Fixed output voltages of 3.3V and 5.0V
2. 96% efficiency
3. Maximum output current = 4 amps
4. User programmable current limit
5. User programmable “soft-start”
6. Enable function for user controlled start-up
7. Low total internal power dissipation

## **Definitions of Voltage Regulator Related Terms**

---

### **A. Quiescent Current/Ground Current (IQ/IGND):**

1. The portion of input current to the regulator which is not delivered to the load.
2. The operating input current of the regulator with no load applied to the output.

### **B. Dropout Voltage**

The input-output differential at which the voltage regulator will no longer maintain regulation. Further reduction in input voltage will result in reduced output voltage. This value is dependent on load current and junction temperature.

### **C. Line Regulation**

The change in output voltage for a specified change in input voltage. This measurement is normally taken under conditions of low power dissipation to reduce the affect of average chip temperature and is typically represented as a percentage of the output voltage.

### **D. Load Regulation**

The change in output voltage for a specified change in load current at constant temperature. This is a pulse test so that chip temperature is not affected. This measurement is also expressed as a percentage of the output voltage.

### **E. Total Power Dissipation**

User calculated dissipation based on device use in actual application.

### **Maximum Power Dissipation (Pd)**

The maximum total device dissipation at which the regulator operates within stated specifications. This is calculated using the formula  $P_d = (V_{IN} - V_{OUT}) I_{OUT} + V_{IN} * I_{GND}$

## F. Ripple Rejection

The ratio of rms input ripple voltage to rms output ripple voltage. This is measured at a specified frequency and load current.

## G. Thermal Terms

See Fig. 1, Thermal Model, for additional information.

1.  $T_J$  - Junction Temperature
2.  $R\theta_{JC}$  - Junction to Case Thermal Resistance
3.  $R\theta_{CS}$  - Case to Heat Sink Thermal Resistance
4.  $R\theta_{SA}$  - Heat Sink to Ambient Thermal Resistance
5.  $T_A$  - Ambient Temperature
6.  $T_C$  - Case Temperature
7.  $T_S$  - Heat Sink Temperature

Thermal Model

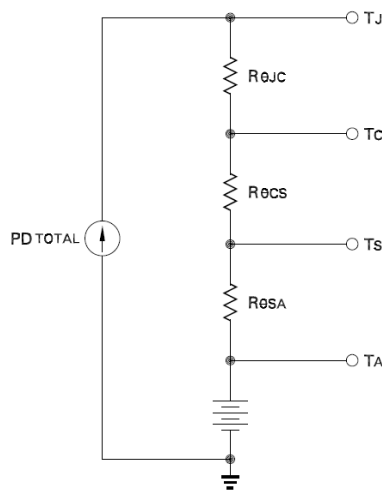

Governing Equation

$$T_J = PD_{Total} * (R\theta_{JC} + R\theta_{CS} + R\theta_{SA}) + T_A$$

Where:

$T_J$  = Junction Temperature

$PD_{Total}$  = Total Power Dissipation

$R\theta_{JC}$  = Junction to Case Thermal Resistance

$R\theta_{CS}$  = Case to Heat Sink Thermal Resistance

$R\theta_{SA}$  = Heat Sink to Ambient Thermal Resistance

$T_A$  = Ambient Temperature

## **Advantages of the Five Pin Package**

---

There are distinct advantages to a five terminal regulator as opposed to a three terminal regulator. One of these advantages is the use of a flag output to monitor the quality of the power to the load. The flag output can be used to indicate low input voltage and over current conditions. For example, when the flag pin is monitored and the output voltage is within a few percent of the desired value, the flag output will stay high indicating a “good” condition. If the output drops more than 8% below the nominal value due to low input voltage or an over current condition, then the flag output drops to indicate a fault condition. This flag output can be designed into a system so as to allow a controller the ability to monitor and make decisions about the readiness of the system.

In addition to the flag output, a five terminal regulator also offers an enable input that is TTL and 5V or 3.3V CMOS compatible. This enable input offers better energy efficiency through the use of “sleep” mode operation. When the input is pulled above approximately 1.4 volts, the regulator is turned on. When the input is low the regulator is inactive and all internal circuitry is biased off, resulting in virtually zero power consumption.

The five pin packaging also allows MS Kennedy to offer a line of dual positive/negative, low dropout fixed voltage regulators, as well as one with ultra low dropout characteristics. These regulators are offered in many different output voltage combinations and the factory should be contacted if alternate voltages would be required.

The MSK 5000 Series of voltages regulators offer a typical positive dropout voltage of approximately 1.3 volts as well as output voltage tolerance of less than 1%. The negative dropout voltage is typically 0.8 volts, also with an output voltage tolerance less than 1%. This line of regulators is rated up to 3 amps.

If ultra low dropout is required, MSK offers the 5200 series of voltage regulators. Positive dropout is typically 350mV. While negative dropout is 550mV, output voltage tolerance is less than 1% for both positive and negative regulators. These regulators are also rated up to 3 amps.

In addition to the 5 pin packaging available, MS Kennedy also offers voltage regulators in a 3 pin hermetic, surface mount package, an extremely compact 10 pin SOIC package and a 12 pin power dip package. The MSK 5215, 5230, 5250 and 5275 are all designed into a space efficient 3 pin power surface mount ceramic package. This package design has a high thermal conductivity and very short internal thermal junctions allowing for the use of standard surface mount soldering techniques. Additional heat sinking may be required depending on the operating output current.

The MSK 5100 Series is offered in the space efficient 10 pin power SOIC package with a built in copper/moly heat sink tab. These devices also offer very short thermal paths and excellent thermal conductivity. Standard surface mount techniques may be used when soldering to a printed circuit board and since the heat sink and lid are connected to ground, the ground plane may be used to help dissipate heat.

When higher output current is required, the MSK 5020 and 5021 are excellent choices as they achieve output currents up to 20 amps. They are both packaged in the 12 pin power dip package that offers very good thermal conductivity and heat sinking options. The additional pins in this packaging option also allows MS Kennedy to offer a programmable current limit, TTL enable, as well as a regulation dropout Fault pin.

MS Kennedy also offers single supply voltage regulators with adjustable output voltages. These regulators do have the enable, however the flag output pin has been converted to an adjust pin. Through the use of two external resistors, the output voltage may be programmed from 1.25V up to VIN. VIN must remain within absolute maximum ratings.

The resistor values for R1 & R2 are calculated using the following formula.

$$R1 = R2 \times \frac{V_{OUT}}{1.240} - 1$$

The resistor values can be quite large due to the high input impedance and low bias current of the sense comparator. Keep in mind that the resistors selected must draw the minimum load current of 10 mA for proper operation.

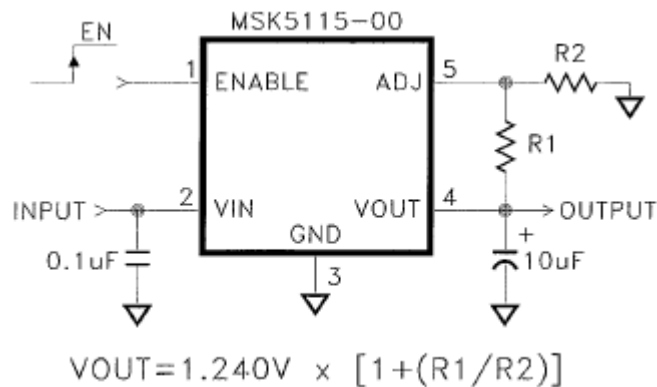



## Capacitor Selection

---

### *Input Capacitors*

The MSK low dropout voltage regulators require an input bypass capacitor to accommodate for wide changes in load current. Also, input capacitors are needed on some regulators for decoupling of the error amplifiers and charge pumps. A medium to large value low-ESR (equivalent series resistance) capacitor is best. This capacitor should be mounted close to the device. Where a regulator is powered from a source with a high AC impedance, it is recommended that a 0.1  $\mu$  F capacitor is also connected between the input and ground. This capacitor should have good characteristics to above 250 KHZ.

### *Output Capacitors*

For stability and minimum output noise on the MSK voltage regulators it is necessary to add an external capacitor from the regulator output to ground. It is not necessary to use expensive low-ESR type capacitors as aluminum electrolytics will perform adequately. In fact, low-ESR capacitors may contribute to instability. The optimum value of this capacitor may vary from one application to another, so experimentation may be required to determine the best value. It should be noted that 10  $\mu$  F is a good starting point for this experimentation. The capacitor will also improve transient load response. Where fast transient load response is required, tantalum capacitors are recommended for the output.

## Thermal Issues

---

MS Kennedy super low dropout and ultra low dropout voltage regulators are very easy to use in most applications. Thermal designs for these regulators are also quite simple, due to the low dropout. However, it must be noted that at higher load currents, thermal considerations become very important. The output pass transistors are rated to dissipate large amounts of power but the effective dissipation of the heat generated at these levels is the limiting factor for these devices. Junction temperature and heat dissipation must be taken into account when using these regulators.

You must first calculate the total power dissipation (Pd) for your application. This can easily be done with the following formula:

$$\text{Total Power Dissipation (Pd)} = (V_{\text{IN}} - V_{\text{OUT}}) I_{\text{OUT}} + V_{\text{IN}} * I_{\text{GND}} \quad (\text{Note 1})$$

As an example, we will use the MSK 5275 –3.3 voltage regulator.

Given:

$$V_{IN} = +5 \text{ VDC}$$

$$V_{OUT} = +3.3 \text{ Volts}$$

$$I_{OUT} (\text{MAX}) = 7.5 \text{ Amps}$$

$$I_{GND} = 120 \text{ mA (consult data sheet)}$$

To calculate Pd, simply substitute these values into the above formula

$$Pd = (V_{IN} - V_{OUT}) I_{OUT} + V_{IN} * I_{GND}$$

$$Pd = (5V - 3.3V) 7.5A + (5V * 120 \text{ mA})$$

$$Pd = 13.35$$

Next, it is important to select a maximum junction temperature (Tj). This value will be located in the MSK data sheet. Absolute maximum allowable junction temperature is 175°C. However, a junction temperature of 150°C is a more suitable choice for these calculations. In most cases, a heat sink would be selected using this data. The selection of a suitable heat sink can be performed with the following formula for convective heat flow:

$$T_j = Pd \times (R_{\theta_{JC}} + R_{\theta_{CS}} + R_{\theta_{SA}}) + T_a$$

The variables of the above formula are:

Tj = Junction Temperature

Pd = Total Power Dissipation

R $\theta_{JC}$  = Junction to Case Thermal Resistance (located in the MSK Data Sheet)

R $\theta_{CS}$  = Case to Heat Sink Thermal Resistance (typically 0.15°C/W)

R $\theta_{SA}$  = Heat Sink to Ambient Thermal Resistance (value to be solved for)

Ta = Ambient Temperature

Rearrange the above formula to solve for R $\theta_{SA}$ :

$$R_{\theta_{SA}} = \frac{T_j - T_a}{Pd} - R_{\theta_{JC}} - R_{\theta_{CS}}$$

Once the formula has been solved for R $\theta_{SA}$ , then this value can be used to locate a heat sink with a thermal resistance less than R $\theta_{SA}$ . Choosing a heat sink thermal resistance less than R $\theta_{SA}$  will maintain Tj at less than your chosen value.

For Example:

The MSK voltage regulator from the power dissipation example above requires a heat sink. This is how we find the thermal resistance of that heat sink:

$T_j = 150^\circ\text{C}$  (chosen below the maximum  $T_j$ )  
 $P_d = 13.35$  watts (from above example)  
 $R_{\theta_{JC}} = 1.2^\circ\text{C/W}$  (found in data sheet)  
 $R_{\theta_{CS}} = 0.15^\circ\text{C/W}$  (this is typical for most thermal greases)  
 $T_a = 25^\circ\text{C}$

Solve for  $R_{\theta_{SA}}$ :

$$R_{\theta_{SA}} = \frac{150^\circ\text{C} - 25^\circ\text{C}}{13.35\text{W}} - 1.2^\circ\text{C/W} - 0.15^\circ\text{C/W}$$

$$R_{\theta_{SA}} = 9.36^\circ\text{C/W} - 1.05^\circ\text{C/W}$$

$$R_{\theta_{SA}} = 8.3^\circ\text{C/W}$$

With the results from this calculation it is now possible to find a heat sink that will maintain the junction temperature at or below the chosen maximum, up to 7.5 amps of load current.

It may be found that the heat sink required for an application is either too large, too expensive or both. If this is the case, it is possible to take advantage of the low dropout voltages exhibited by the MSK voltage regulators. A series resistor can be used on VIN to help dissipate some power externally. The overall voltage drop, as well as heat, is distributed between the low cost external resistor and the regulator. This allows for a reduction in the size of the required heat sink. All that is needed for calculation of series resistor value is the worst case voltages in the system and the peak currents required. With this information we will be able to select a resistor that will drop a portion of the excess voltage with no performance sacrifice. Use the following formula to calculate the maximum value for the external resistor.

$$R_{\text{MAX}} = \frac{V_{\text{IN(MIN)}} - V_{\text{OUT(MAX)}} + V_{\text{DO}}}{I_{\text{OUT(PEAK)}} + I_{\text{GND}} \text{ (Note 1)}}$$

For Example:

Using the MSK voltage regulator from the above examples we know that:

$$V_{\text{IN(MIN)}} = (5\text{V} - 5\%) = 4.75\text{V}$$

$$V_{\text{OUT(MAX)}} = \text{Maximum output voltage across the full temperature range} \\ = (3.3\text{V} + 2\%) = 3.366\text{V}$$

$$V_{\text{DO}} = \text{Worst case dropout across the full temperature range} = 600 \text{ mV}$$

$$I_{\text{OUT(PEAK)}} = \text{Maximum load current} = 7.5 \text{ Amps}$$

$$I_{\text{GND}} = \text{Ground current (found in data sheet if necessary)} = 120 \text{ mA}$$

Solve for the resistor value:

$$R_{MAX} = \frac{4.75V - 3.366V + 0.6V}{7.5A + 0.12A}$$

$$R_{MAX} = 0.10\Omega$$

Now we can calculate the power drop across this resistor using:

$$\begin{aligned} P_{dRES} &= (I_{OUT(PEAK)} + I_{GND})^2 * R \\ P_{dRES} &= (7.5A + .12A)^2 * 0.10 \Omega \\ P_{dRES} &= 5.8W \end{aligned}$$

This 5.8w subtracts directly from the total power dissipation found without the series resistor, reducing the regulator power dissipation to 7.6 watts. It can be seen that our heat sinking requirements have dropped considerably. They should be recalculated for a smaller heat sink with a larger thermal resistance.

Note 1:  $I_{GND}$  may or may not be required for all MSK voltage regulator designs. Consult individual data sheets for this information. If  $I_{GND}$  is not needed for the calculation then the  $(V_{IN} * I_{GND})$  factor must be discarded from the formula.

## **Lead Form Options**

In addition to various package styles, MSK offers a variety of lead form options. All 5 pin power and TO-254 style packages are available with leads straight, bent up, or bent down. These packages are also available with a surface mount lead form option. This option allows the device to be soldered into a system without lead insertion. All optional lead form drawings except surface mount can be found in the individual regulator data sheets. The surface mount lead form drawings are included here. If custom lead form is required, please contact MS Kennedy for further information.

***Additional Surface Mount Lead Form Options for Standard MSK Regulator and Power Amplifiers***

5-PIN TOP TAB

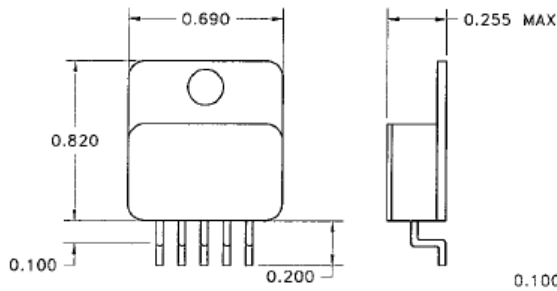

5-PIN Z TAB

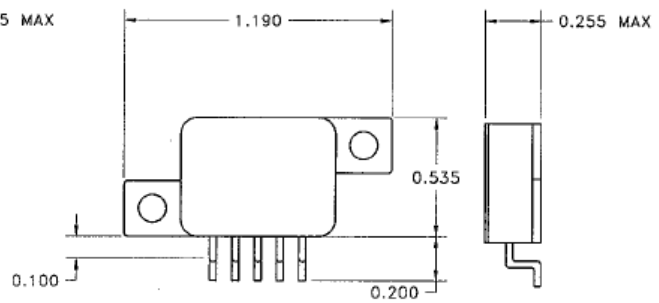

8-PIN NO TAB

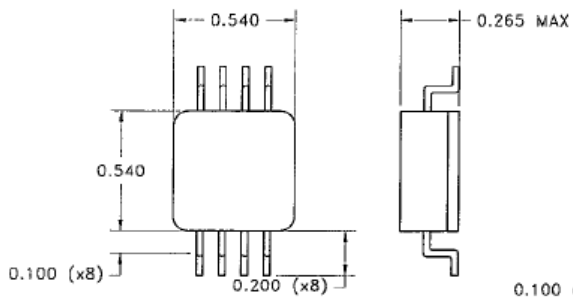

8-PIN Z TAB

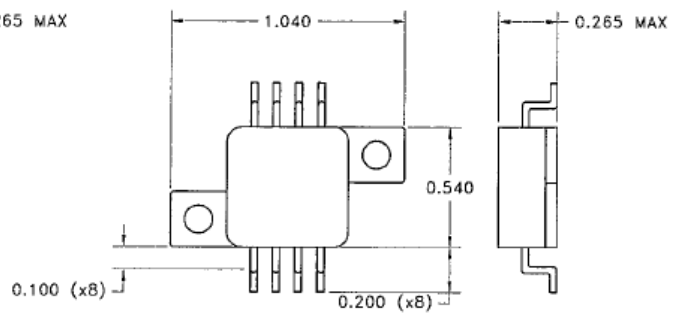

6-PIN NO TAB

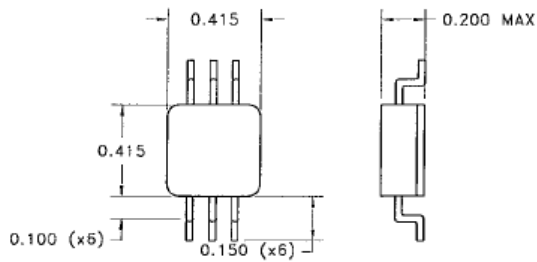

6-PIN SIDE TAB

