

Xinger® III

1:1 Inverted Doherty Combiner



Description

The X3DC09F1AS is a low profile, high performance Doherty Combiner in a new easy to use, manufacturing friendly surface mount package. The X3DC09F1AS is designed particularly for Doherty Amplifier applications, where a tightly controlled phase of 90 degrees, 1:1 splitting ratio and low insertion loss are required for maximum and low power condition. It can be used in high power applications.

Parts have been subjected to rigorous qualification testing and they are manufactured using materials with coefficients of thermal expansion (CTE) compatible with common substrates such as FR4, RF-35, RO4350 and polyimide. Produced with 6 of 6 RoHS compliant tin immersion finish

Features:

- 920-960 MHz
- Low Amp Imbalance
- Low Loss
- Production Friendly
- Tape and Reel
- Lead Free

Electrical Specifications **

Frequency	Return Loss [1]	Insertion Loss [1]	Amplitude Imbalance [1]	Phase Imbalance [1]
MHz	dB Min	dB Max	dB Max	Degrees
920-960	23	0.3	±0.3	90 ± 4.0
Operating Temp.	Return Loss [2]	Insertion Loss [2]	Port Extension [3]	Power [4]
°C	dB Min	dB Max	Degrees	Avg. CW Watts @105°C
-55 to +150	23	0.3	0	20

**Specification based on performance of unit properly installed on Anaren TTM Test Board

[1] At maximum power condition, Doherty combiner functions as a 1:1 power combiner.

[2] At low power condition, Doherty combiner works as an impedance transformer (see page 4)

[3] At low power condition, the offset lines at the input need to be adjusted by 0 deg. (if required) (see page 4)

[4] 20W output from each PA for short duration @ max power condition. Details in page 5.

Mechanical Outline

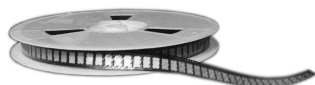
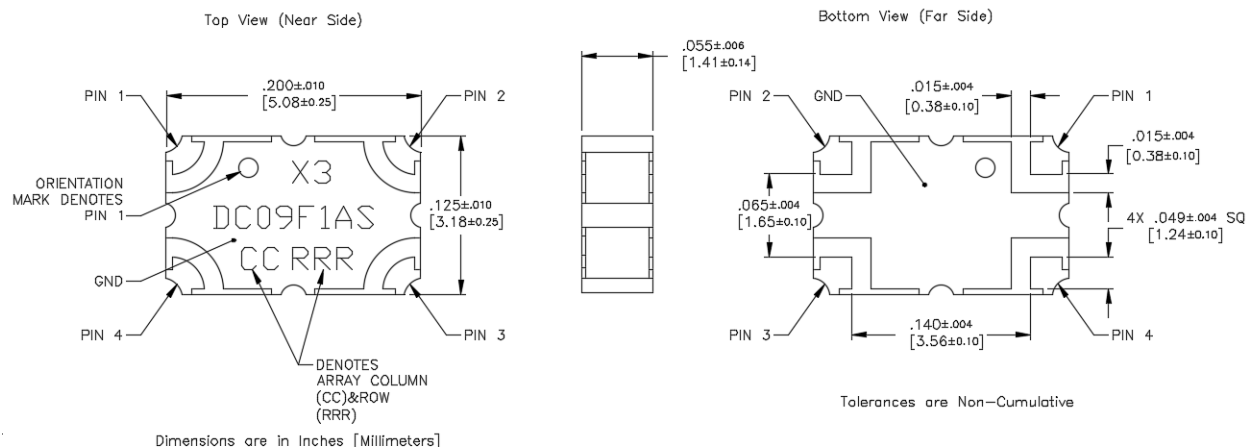

Doherty Amplifier Configuration

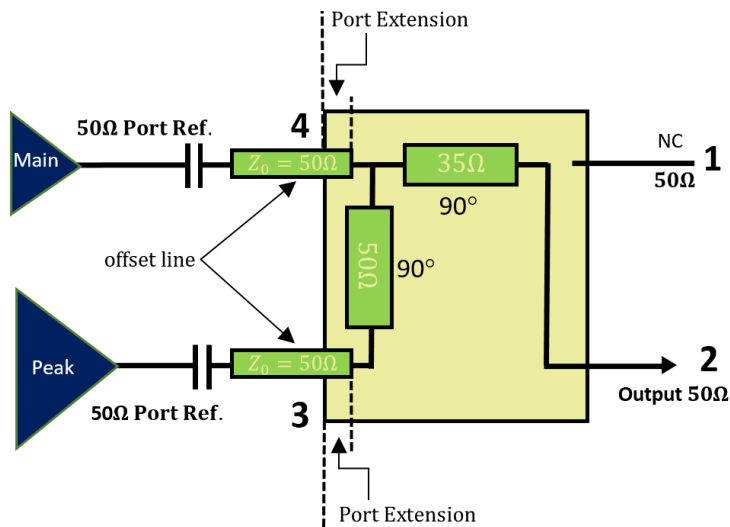

1:1 Inverted Doherty Combiner

Doherty Combiner Pin Configuration

The X3DC09F1AS has an orientation marker to denote Pin 1. Once port one has been identified the other ports are known automatically. Please see the chart below for clarification:

Pin 1	Pin 2	Pin 3	Pin 4
Not Connected	Combining Port	Peak Amp Port	Main Amp Port

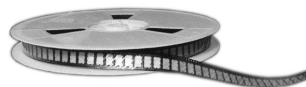

Insertion Loss and Power Derating Curves

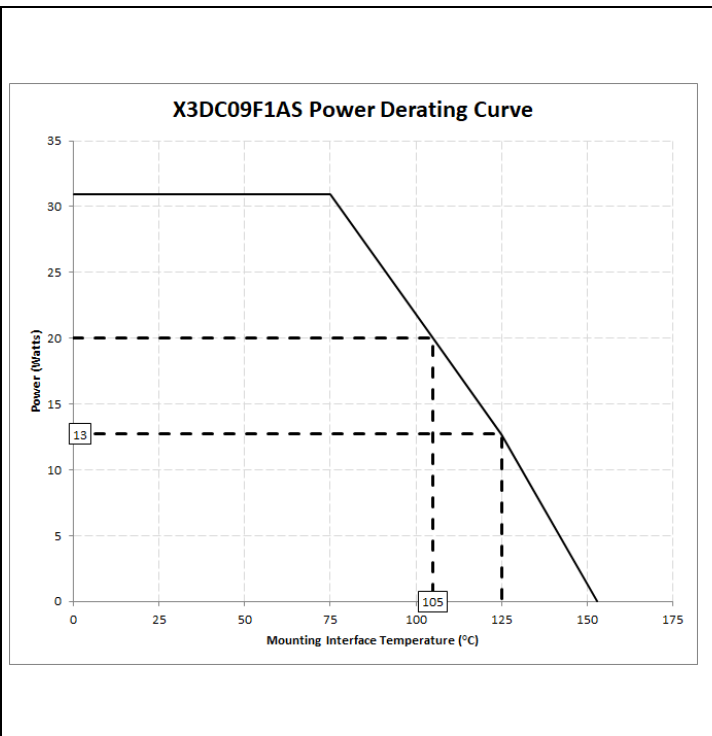
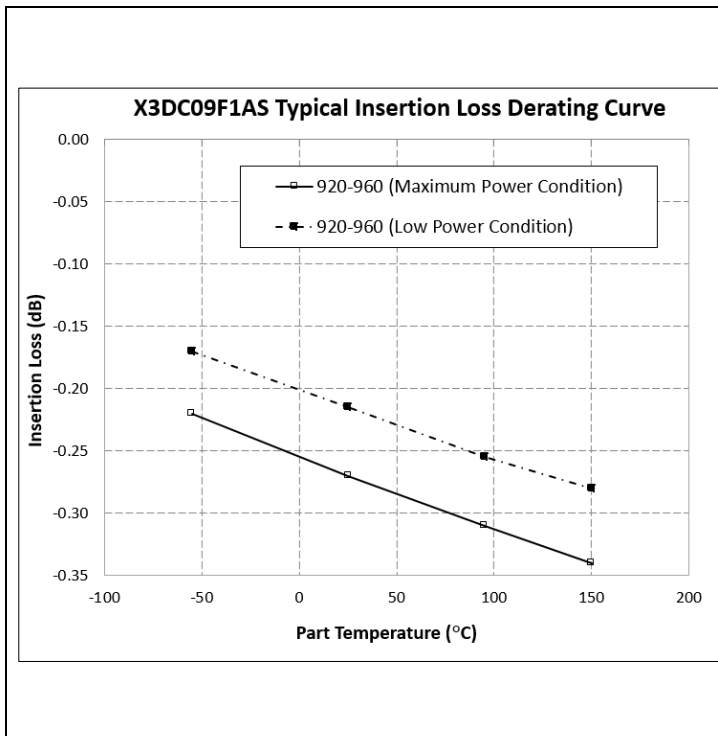

Insertion Loss Derating:

The insertion loss, at a given frequency, of a group of doherty combiners is measured at 25°C and then averaged. The measurements are performed under small signal conditions (i.e. using a Vector Network Analyzer). The process is repeated at 95°C and 150°C. A best-fit line for the measured data is computed and then plotted from -55°C to 150°C.

Power Derating:

The power handling and corresponding power derating plots are a function of the thermal resistance, mounting surface temperature (base plate temperature), maximum continuous operating temperature of the Doherty combiner, and the thermal insertion loss. The thermal insertion loss is defined in the Power Handling section of the data sheet.

As the mounting interface temperature approaches the maximum continuous operating temperature, the power handling decreases to zero.

If mounting temperature is greater than 105°C, Xinger doherty combiner will perform reliably as long as the input power is derated to the curve above.

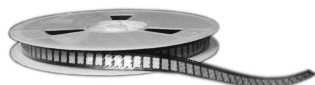

Typical Performance (-55°C, 25°C, 95°C, and 150°C): 920-960MHz

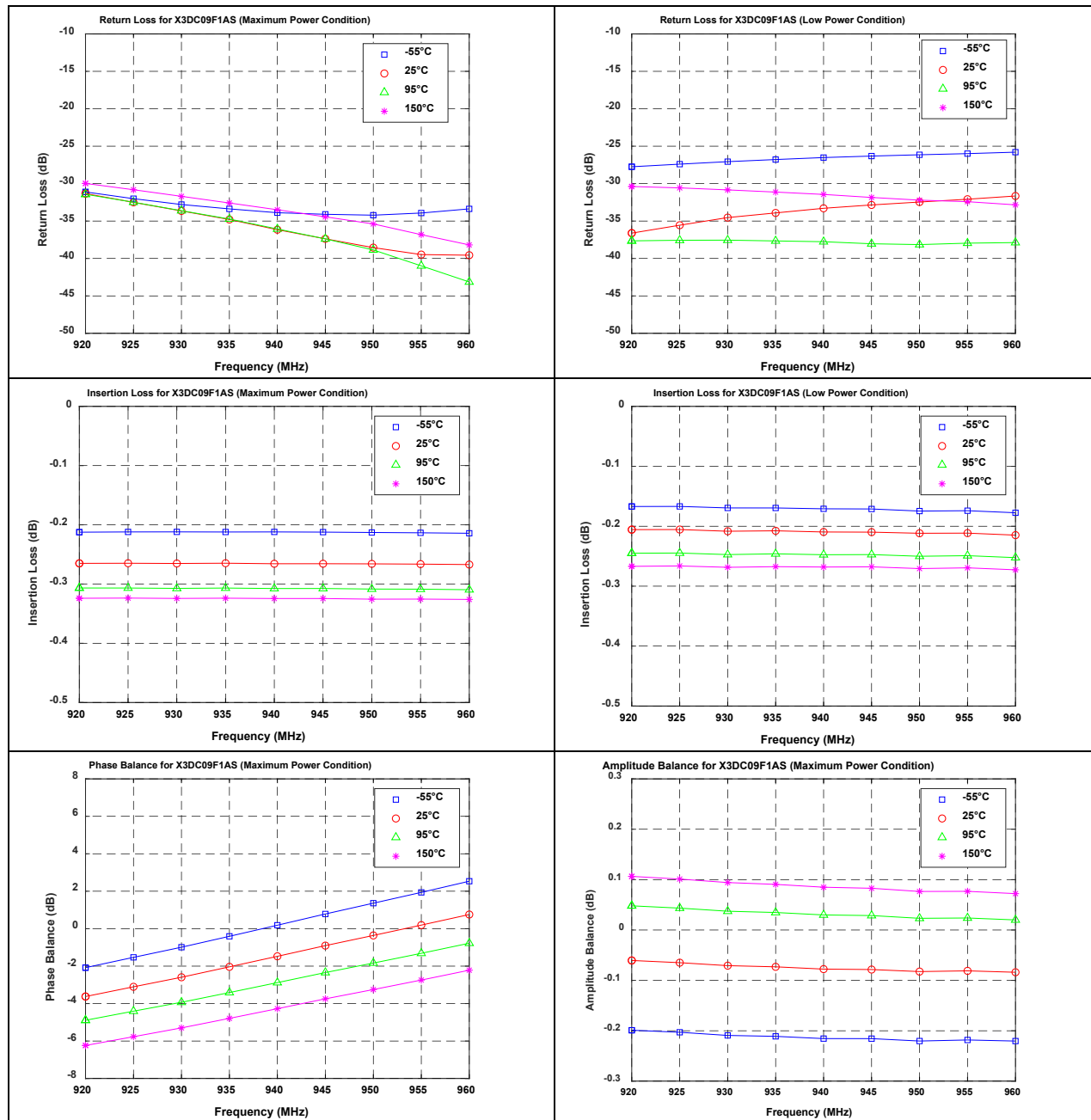

USA/Canada: (315) 432-8909
 Toll Free: (800) 411-6596
 Europe: +44 2392-232392

Available on Tape and Reel for Pick and Place Manufacturing.

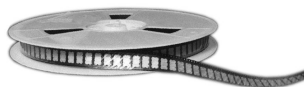

Anaren
 What'll we think of next?®

Definition of the Specifications

To guarantee the part performance in Doherty architecture, the part is specified in Doherty operation for maximum power condition and low power condition. The following specification definition assumes the extra port extension is already applied to the raw S parameter and the parts is measured with Pin n connected to Port n (where n=1, 2, 3, 4).

- **Maximum power condition**

Under the maximum power condition, the Doherty architecture requires main amplifier and peak amplifier to work at full capacity with Main at 50Ω and Peak at 50Ω. The two amplifiers should deliver RF power ratio of 1:1 and 90 degree phase difference.

Parameter	Definition	Mathematical Representation
Return Loss	The impedance match at the combining port to a 50Ω system.	$20 \log S_{22} $
Insertion Loss	The combined power divided by the sum of input power under the perfect combining condition.	$10\log(S_{23}^2 + S_{24}^2)$
Amplitude Imbalance	The magnitude difference between Main-Combined path and Peak-Combined path under the perfect combining condition.	$\frac{20\log S_{24} - 20\log S_{23} }{2}$
Phase Imbalance	The phase difference between Peak-Combined path and Main-Combined path at $\omega_c = 940\text{MHz}$.	$\text{Phase}(S_{24}(\omega_c)) - \text{Phase}(S_{23}(\omega_c))$

- **Low power condition**

Under low power condition, the Doherty operation turns off peak amplifier and requires main amplifier to be terminated with impedance of 25Ω. In this configuration, Doherty combiner serves as an impedance transformer, transforming 50Ω at combining port to 25Ω at main amplifier port. The following specification is defined under the port impedance condition of Port 2 (Combining Port) 50Ω, Port 4 (Main Amp Port) 25Ω and Port 3 (Peak Amp Port) terminated with a short (low impedance).

- **Port Extension:** There are inevitably short lines associating with input ports in some high frequency band parts. The length of the short line is specified as electrical length at center frequency and referred as port extension in this datasheet. The designer should take this length into the account to optimize the offset line length. The return loss and insertion loss specified in the Electrical Specifications table are after incorporating port extension.

Parameter	Definition	Mathematical Representation
Return Loss	The impedance match of the 50Ω to 25Ω transformer.	$20 \log S_{22} $
Insertion Loss	The output power divided by input power.	$20\log S_{24} $

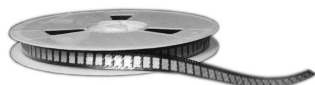

Mounting Footprint

To ensure proper electrical and thermal performance there must be a ground plane with 100% solder connection underneath the part orientated as shown with text facing up.

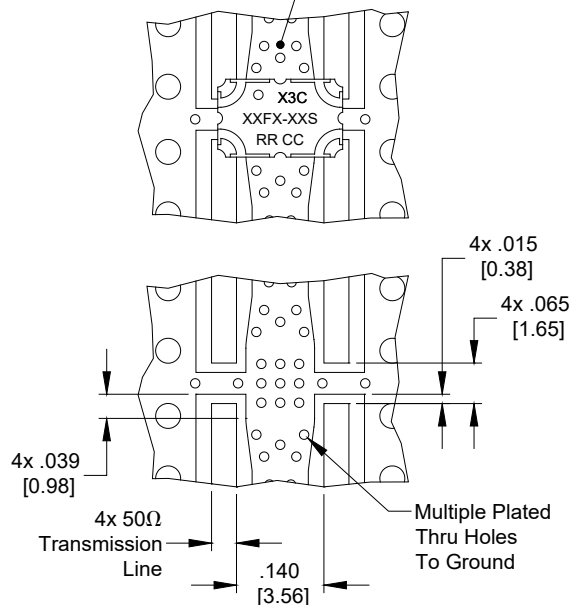

Dimensions are in Inches [Millimeters]
X3CXXFX-XXS Mounting Footprint

Doherty Power handling

Doherty power amplifiers are capable of amplifying the signals of high Peak to Average Ratio (PAR) with high efficiency. A 1:1 symmetrical Doherty architecture is typically used for signals of 6-10dB PAR.

To evaluate power handling capability, the doherty combiner is analyzed in different conditions of varying PAR that the component would see in its lifetime.

Condition 1: In symmetrical Doherty application, at average power condition, the Doherty amplifier works at back off mode and turns on only main amplifier with half of its full power capacity. The thermal condition of Anaren Doherty combiner is evaluated as an impedance transformer.

X3DC09F1AS can handle reliably for life 10W at main amplifier and 0W at peak amplifier when evaluated as impedance transformer.

Condition 2: Doherty amplifier ramps up the main amplifier to 65% its full power capacity and peak amplifier to 30% of its full power capacity, outputting power roughly 3dB above the average. The thermal condition of Anaren Doherty combiner is analyzed as a coherent combiner and such power level is assumed continuously over entire life span of the component. Although conservative and limit the components power rating, it is done so to guarantee the life time of the components over high PAR signals.

X3DC09F1AS can handle reliably for life 13W at main amplifier and 6W at peak amplifier when evaluated for condition 2.

Condition 3: Signals of 3dB and above the average power occur with low probability and short duration and they do not present thermal risk. With high breakdown voltage, Anaren Doherty combiners can safely withstand at least 12dB peaks over the average rated power.

X3DC09F1AS can handle reliably for life 20W at main amplifier and 20W at peak amplifier when evaluated for peak pulses of very short duration.

The power handlings of Anaren Doherty combiners are conservatively rated at averaged power with high PAR signal and Doherty operation in mind. The combiners can be used in Doherty amplifiers of rated average output power. No further power derating for high PAR signals is required

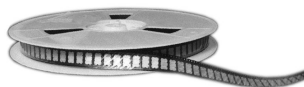

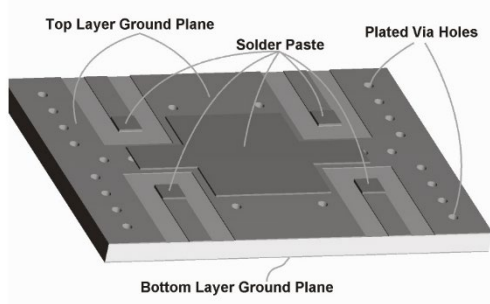

Figure 2: Solder Paste Application

Reflow: The surface mount doherty combiner is conducive to most of today's conventional reflow methods. A low and high temperature thermal reflow profile are shown in Figures 5 and 6, respectively. Manual soldering of these components can be done with conventional surface mount non-contact hot air soldering tools. Board pre-heating is highly recommended for these selective hot air soldering methods. Manual soldering with conventional irons should be avoided.

Doherty combiner Positioning: The surface mount doherty combiner can be placed manually or with automatic pick and place mechanisms. Doherty combiners should be placed (see Figure 3 and 4) onto wet paste with common surface mount techniques and parameters.

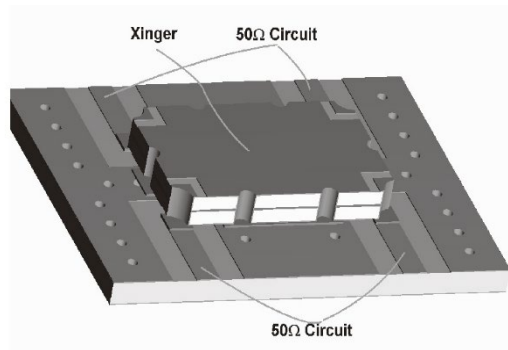

Figure 3: Component Placement

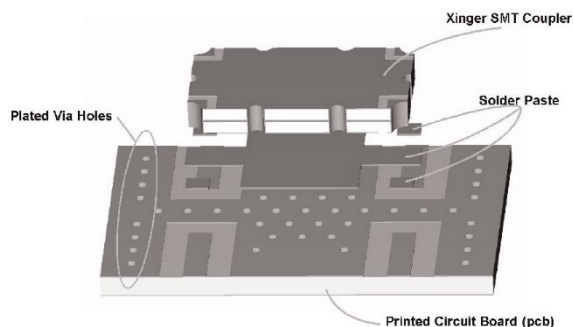
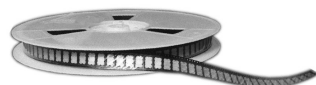

Figure 4: Mounting Features Example



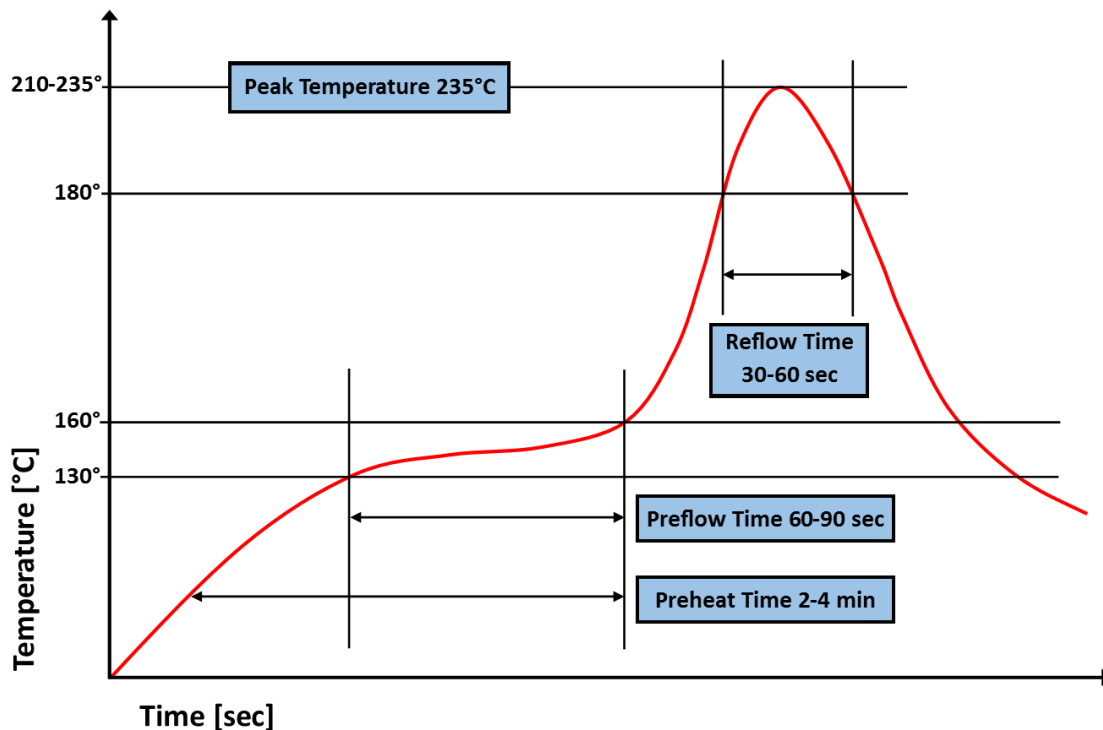

Figure 5 – Low Temperature Solder Reflow Thermal Profile

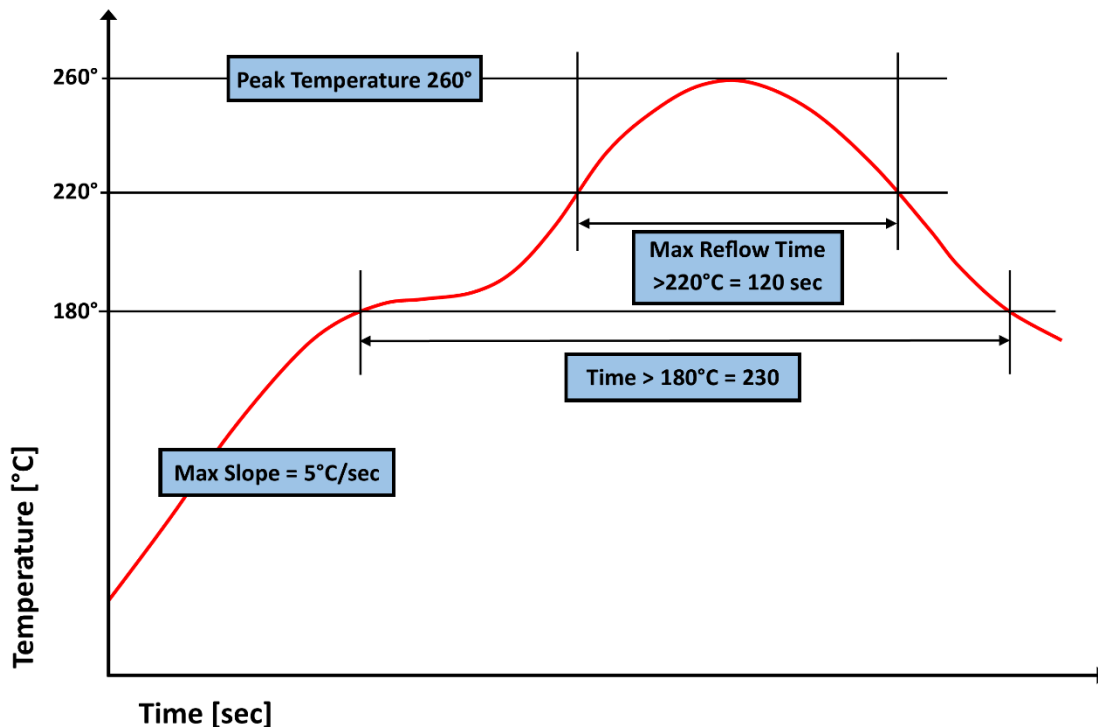
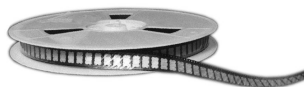
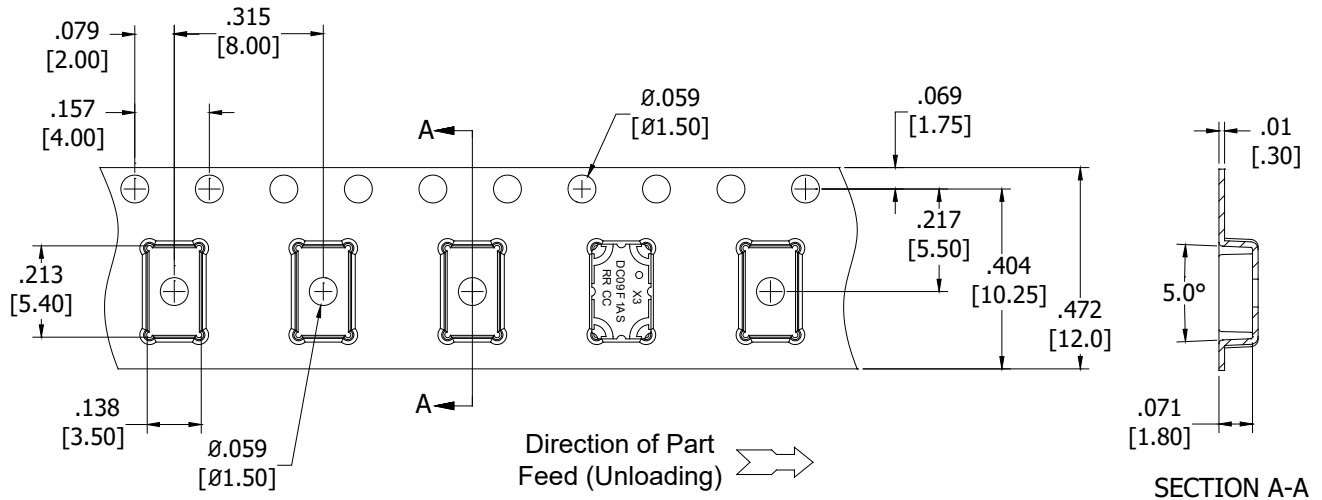

Figure 6 – High Temperature Solder Reflow Thermal Profile



Packaging and Ordering Information

Parts are available in reels. Packaging follows EIA 481-D for reels. Parts are oriented in tape and reel as shown below. Tape and reel is available in 4000 pcs per reel.



Dimensions are in Inches [Millimeters]

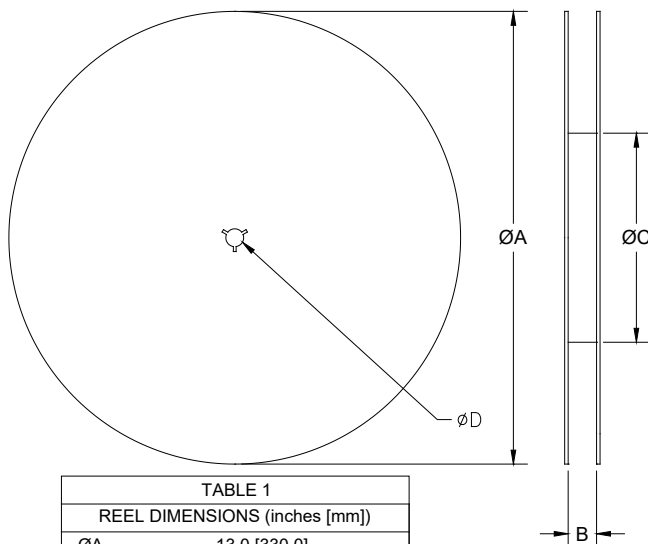

TABLE 1	
REEL DIMENSIONS (inches [mm])	
ØA	13.0 [330.0]
B	.945 [24.0]
ØC	4.017 [102.03]
ØD	0.512 [13.0]

