



36V, 2A,
2.0MHz STEP-DOWN
SWITCHING REGULATOR
CONTROLLER

5031

FEATURES:

- Wide Input Range: 3.6V to 36V
- 2A Integrated Switch
- Adjustable Switching Frequency: 200KHz to 2.0MHz
- Synchronizable Switching Frequency: 250KHz to 2MHz
- Low Quiescent Current
- Shutdown Quiescent Current < 1uA
- Output Voltage Range: 0.79V to 20V
- Power Good Flag
- Contact MSK for MIL-PRF-38534 Qualification Status

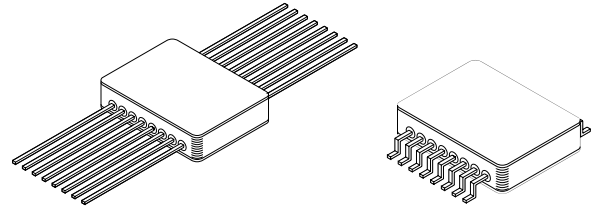

DESCRIPTION:

The MSK5031 is a 200KHz to 2.0MHz step-down switching regulator controller with a high efficiency 0.25Ω integrated switch. Synchronized or fixed high frequency switching coupled with wide input and output voltage ranges allows the designer to minimize the required board space for supporting components. With no load quiescent currents typically less than 100uA efficiency remains high at light loads. The shutdown circuitry allows the user to further reduce the input voltage supply current to less than 1uA. The MSK5031 is packaged in a hermetically sealed 16 pin flatpack and is available with a straight or gull wing lead form.

EQUIVALENT SCHEMATIC

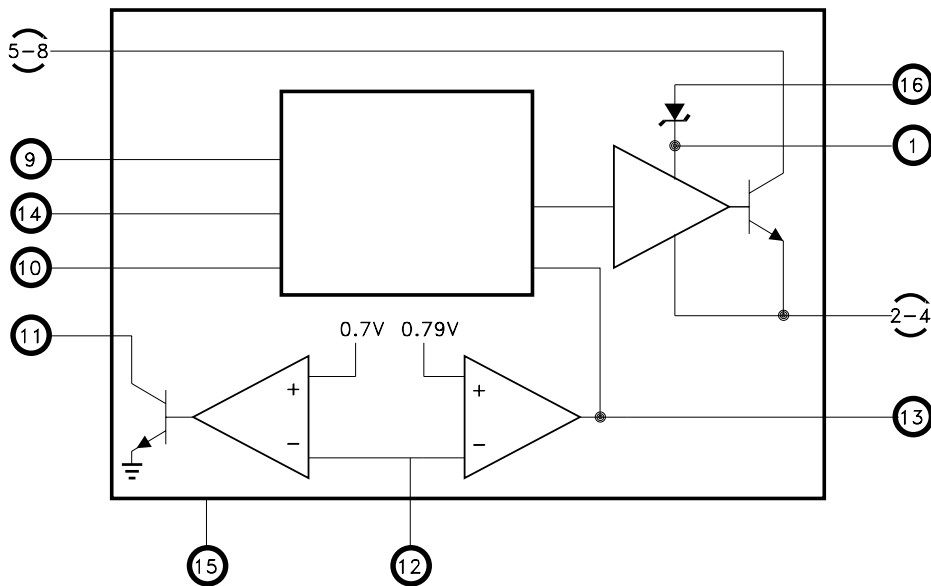

TYPICAL APPLICATIONS

- POL Applications
- System Power Supply
- Microprocessor, FPGA Power Source
- High Efficiency Low Voltage Subsystem Power Supply

PIN-OUT INFORMATION

1 BOOST	16 BD
2 SW	15 GND
3 SW	14 RT
4 SW	13 VC
5 VIN	12 FB
6 VIN	11 PGOOD
7 VIN	10 SYNC
8 VIN	9 RUN/SS

CASE=ISOLATED

ABSOLUTE MAXIMUM RATINGS ^⑦

VIN, RUN/SS Voltage	36V	TJ Junction Temperature	+150°C
IOUT Output Current	2A	TST Storage Temperature Range ^⑧	-65°C to +150°C
BOOST Pin Voltage	36V	TLD Lead Temperature Range	
BOOST Pin Above SW Pin	30V	(10 Seconds)	300°C
FB, RT, VC Voltage	5V	TC Case Operating Temperature	
PG, BD, SYNC Voltage	30V	MSK5031	-40°C to +85°C
		MSK5031H	-55°C to +125°C

ELECTRICAL SPECIFICATIONS

Parameter	Test Conditions ^①	Group A Subgroup	MSK5031H			MSK5031			Units
			Min.	Typ.	Max.	Min.	Typ.	Max.	
Minimum Input Voltage	Switching starts	1,2,3	-	3	3.6	-	3	3.6	V
Quiescent Current From VIN	VBD=3V, Not Switching	1,2,3	-	30	100	-	30	100	uA
Quiescent Current From BD ^②	VBD=3V, Not Switching	1,2,3	-	80	120	-	80	120	uA
Minimum Bias Voltage (BD Pin)		1	-	2.7	3	-	2.7	3	V
Feedback Voltage (VFB)		1	780	790	800	780	790	800	mV
		2,3	775	-	805	-	-	-	mV
FB Pin Bias Current	VFB=0.8V, VC=0.4V	1,2,3	-30	7	30	-30	7	30	nA
FB Voltage Line Regulation	4V<VIN<36V	1	-	0.002	0.01	-	0.002	0.01	%/V
VC Clamp Voltage ^②		1	-	2	-	-	2	-	V
Switching Frequency	RT=29.4K	4	0.9	1	1.15	0.9	1	1.15	MHz
Minimum Switch OFF Time		4,5,6	-	60	150	-	60	150	nS
Switch Current Limit	Duty Cycle=5%	1	3	3.5	4	3	3.5	4	A
Switch VCESAT ^②	ISW=2A	1	-	500	-	-	500	-	mV
BOOST Schottky Reverse Leakage ^②	VSW=10V, VBD=0V	1	-	0.02	2	-	0.02	2	uA
Minimum BOOST Voltage ^②		1,2,3	-	1.5	2.1	-	1.5	2.1	V
BOOST Pin Current ^②	ISW=1A	1	-	22	35	-	22	35	mA
RUN/SS Pin Current ^②	VRUN/SS=2.5V	1	-	5	10	-	5	10	uA
RUN/SS Input Voltage High		1	-	-	2.5	-	-	2.5	V
RUN/SS Input Voltage Low		1	0.2	-	-	0.2	-	-	V
PG Threshold Offset From Feedback Voltage ^②		1	-	100	-	-	100	-	mV
PG Hysteresis ^②		1	-	12	-	-	12	-	mV
PG Leakage	IPG≤1uA, VPG=5V	7	-	-	-	-	-	-	P/F
PG Sink Current	VPG=0.4V	1,2,3	100	600	-	100	600	-	uA
SYNC Low Threshold		1	0.5	-	-	0.5	-	-	V
SYNC High Threshold		1	-	-	0.7	-	-	0.7	V
SYNC Pin Bias Current ^②	VSYNC=0V	1	-	0.1	-	-	0.1	-	uA
Thermal Resistance ^②	Junction to Case@125°C	-	-	12.4	14.8	-	12.4	14.8	°C/W

NOTES:

- ① Unless otherwise specified VIN=10V, VRUN/SS=10V, VBD=3.3V.
- ② Guaranteed by design but not tested. Typical parameters are representative of actual device performance but are for reference only.
- ③ Industrial grade devices shall be tested to subgroup 1 and 4 unless otherwise specified.
- ④ Military grade devices ("H" Suffix) shall be 100% tested to subgroups 1,2,3,4,5,6 and 7.
- ⑤ Subgroup 5 & 6 testing available on request.
- ⑥ Subgroup 1,4,7 TC=+25°C
Subgroup 2,5 TC=+125°C
Subgroup 3,6 TC=-55°C
- ⑦ Continuous operation at or above absolute maximum ratings may adversely effect the device performance and/or life cycle.
- ⑧ Internal solder reflow temperature is 180°C, do not exceed.

APPLICATION NOTES

PIN FUNCTIONS

VIN - The VIN pins connect to the collector of the internal power switch and provide power to the internal control circuitry and internal regulator. Very high di/dt is seen at these pins during switch on and off transitions. High frequency decoupling capacitors are recommended to minimize voltage spikes. All four VIN pins should be connected to a low impedance source for best operation.

SW - The SW pins are connected to the emitter of the internal power transistor. These pins rise up to the input voltage during the on time of the switch and are driven negative when the power switch turns off. The negative voltage is clamped by the catch diode and must not go more negative than -0.8V. All three SW pins must be connected for maximum performance.

BOOST - The BOOST pin provides drive voltage greater than VIN to the base of the power transistor. Using a voltage greater than VIN ensures hard saturation of the power switch, significantly improving overall efficiency. Connect a capacitor between BOOST and SW to store charge.

FB - The FB (feedback) pin's primary function is to set the output voltage. Use a resistive divider from VOUT to GND to set the voltage at the feedback pin to 0.79V when the output voltage is at the desired level. The FB pin provides two additional functions. When the voltage at the FB pin drops, the switching frequency is reduced and sync is disabled. Reference typical performance curve. The FB pin also controls the PG pin output. Reference PG pin function.

GND - The GND pin provides a return path for all internal control current. It is important that it is at the same voltage potential as the load return to ensure proper regulation. Keep current on the ground between the load and the MSK5031 to a minimum and use heavy copper traces to minimize voltage drops and regulation error.

PGOOD - The PGOOD pin is an open collector output driven by a comparator with a 0.7V reference and the FB pin as its input. PGOOD is a low until the FB pin is 86% of its final voltage. For PGOOD to be valid VIN must be greater than 3.6V and the RUN/SS pin is high. A high level on the PGOOD pin also indicates the regulator is ready for switching frequency synchronization at the SYNC pin.

BD - The BD pin connects to the anode of the BOOST schottky diode. Voltage applied to the BD pin is summed with the Switch voltage to create the BOOST voltage. Reference the BOOST pin description. Voltages on the BD pin larger than 3V will supply current to the internal bias supply replacing VIN as its source. This can improve the regulators efficiency.

RUN/SS - The RUN/SS pin provides for shutting the regulator down and soft-start control. Less than 0.2V on the RUN/SS pin shuts down the regulator. If the RUN/SS pin is greater than 2.5V, the regulator runs in normal mode. Soft-start control is achieved by adding a RC network on the RUN/SS pin. The voltage ramp on the pin reduces the allowable startup current to meet the output voltage requirement without overshoot. Tie RUN/SS to VIN if shutdown and soft-start are not required.

SYNC - The SYNC pin is the input for an external clock source to control the regulators switching frequency. The recommended clock source is a square-wave with 20% to 80% duty cycle. The clock source rise and fall times must be faster than 1uS. The Synchronization range is from 250KHz to 2MHz. The RT pin resistor must be set to a frequency which is 20% below the lowest synchronized frequency. Reference the PGOOD pin description. Tie the SYNC pin to ground when not used.

RT - The RT pin connects to the regulators internal oscillator. A resistor tied from the RT pin to ground sets the regulators switching frequency. Reference the table in the application notes within for required resistor values.

VC - The VC pin is the output of the error amplifier and the input of the peak current comparator. This pin is typically used for frequency compensation. Reference "Compensating The Loop" in the application notes within.

SWITCHING FREQUENCY

The switching frequency is programmed with a single resistor tied from the RT pin to ground. The table below shows the necessary RT value for a desired switching frequency.

SWITCHING FREQUENCY (MHz)	RT VALUE (K Ω)
0.2	187
0.3	121
0.4	88.7
0.5	68.1
0.6	56.2
0.7	46.4
0.8	40.2
0.9	34
1.0	29.4
1.2	23.7
1.4	19.1
1.6	16.2
1.8	13.3
2.0	11.5

SETTING THE OUTPUT VOLTAGE

The output voltage of the MSK5031 is set with a simple resistor divider network: see Figure 1 (Typical Application Circuit). Select the resistor values to divide the desired output down to equal VFB (0.79V nominal) at the FB pin.

$$V_{OUT} = V_{FB} * (1 + R1/R2)$$

$$R1 = R2 * (V_{OUT}/V_{FB} - 1)$$

SELECTING THE INDUCTOR

The inductor is used to filter the square pulses at the SW pin to an acceptable linear ripple. The inductance value will limit the maximum available current at different input and output voltages. See "Maximum Load Current" and "Switch Current Limit" in the typical performance curves section of this data sheet. Determine the peak inductor current as follows:

$$I_{PK} = I_{OUT} + V_{OUT} * (V_{IN} - V_{OUT}) / (2 * f * L * V_{IN})$$

Where:

f = the switching frequency in Hz

L = inductor value in Henries

IPK represents the switch current

Select an inductor that will not saturate at worst case peak current. Calculate the peak to peak inductor current ripple as follows:

$$I_{P-P} = V_{OUT} * (V_{IN} - V_{OUT}) / (f * L * V_{IN})$$

Nearly all of the current ripple will be seen by the output capacitance. See selecting the output capacitor.

APPLICATION NOTES CONT'D

SELECTING THE OUTPUT CAPACITOR

The output capacitor filters the ripple current from the inductor to an acceptable ripple voltage seen by the load. The primary factor in determining voltage ripple is the ESR of the output capacitor. The voltage ripple can be approximated as follows:

$$V_{P-P} = I_{P-P} * ESR$$

The typical ESR range for an MSK5031 application is between 0.05 and 0.20 ohm. Capacitors within these ESR ranges typically have enough capacitance value to make the capacitive term of the ripple equation insignificant. The capacitive term of the output voltage ripple lags the ESR term by 90° and can be calculated as follows:

$$V_{P-P}(CAP) = I_{P-P} / (8 * f * C)$$

Where:

C=output capacitance in Farads

Select a capacitor or combination of capacitors that can tolerate the worst-case ripple current with sufficient de-rating. When using multiple capacitors in parallel to achieve ESR and/or total capacitance sharing of ripple current between capacitors will be approximately equal if all of the capacitors are the same type and preferably from the same lot. Low ESR tantalum capacitors are recommended over aluminum electrolytic. A small amount of ceramic capacitance close to the load to decouple high frequency is recommended.

SELECTING THE CATCH DIODE

Use a schottky diode in the catch diode position because they switch very quickly and have low forward voltage. The diode should be rated for well above the maximum input voltage to account for the full input voltage, transients at the switch node and de-rating requirements. Transients at the switch node can be minimized with careful attention to switching current paths during board layout. The diode must be rated for the worst-case peak voltage and the average current plus any de-rating requirements. The average current can be approximated as follows:

$$I_D = I_{OUT} * (V_{IN} - V_{OUT}) / V_{IN}$$

PROVIDING BOOST DRIVE

The BD pin provides drive greater than VIN for the power transistor. The boost capacitor is charged through the BD pin schottky diode to the BD pin voltage when the power switch is off, see Figure 1. When the power switch turns on the SW node rises to VIN and the boost capacitor supplies current to drive the power transistor. The BD pin can be connected to VIN or Vout providing the BOOST pin voltage is more than 2.3V above the SW pin for best efficiency. Reference absolute maximum ratings for pin voltage maximums. Typically a 0.22µF capacitor will provide sufficient charge but smaller capacitors may be used. The following equation gives an approximation for the absolute minimum value but should be used with caution as it does not take all worst case and secondary factors into consideration.

$$C_{MIN} = (I_{OUT} / 45) * (V_{OUT} / V_{IN}) / f * (V_{OUT} - 2.3V)$$

COMPENSATING THE LOOP

The current mode power stage from the VC node to the SW node can be modeled as a transconductance of gm=3.5A/V. The DC output gain will be the product of the transconductance times the load resistance. As frequency increases the output capacitance rolls off the gain until the ESR zero is reached. The error amplifier can be modeled as a transconductance amplifier with gm=400µMho and gain of 1000 with finite output impedance. Typically a resistor and capacitor in series to ground are all that is needed to compensate the loop but more complex compensation schemes are readily achieved.

TYPICAL APPLICATION CIRCUIT

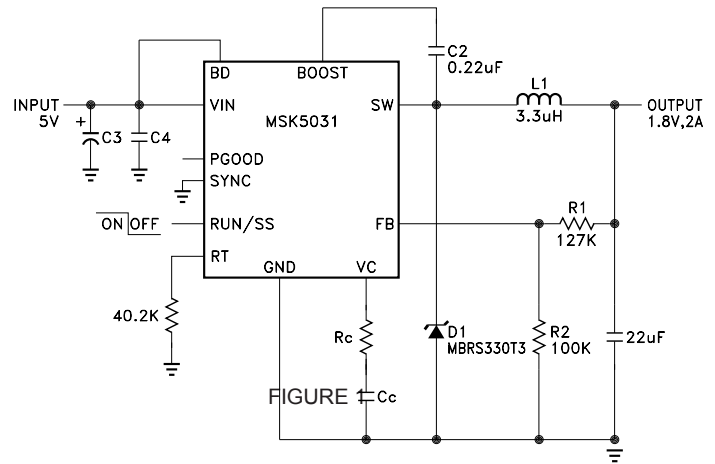

TYPICAL PERFORMANCE CURVES

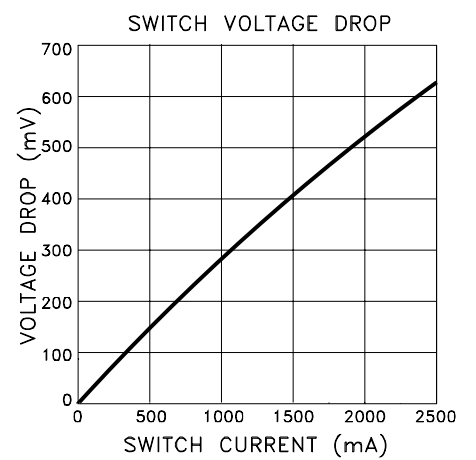
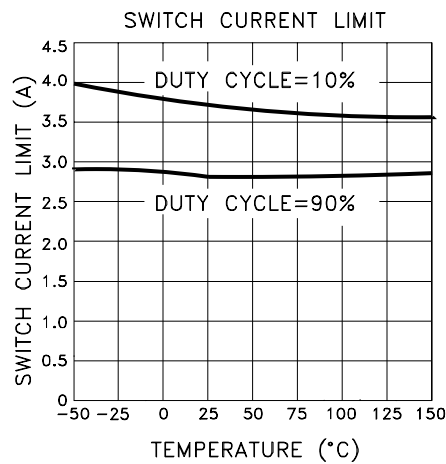
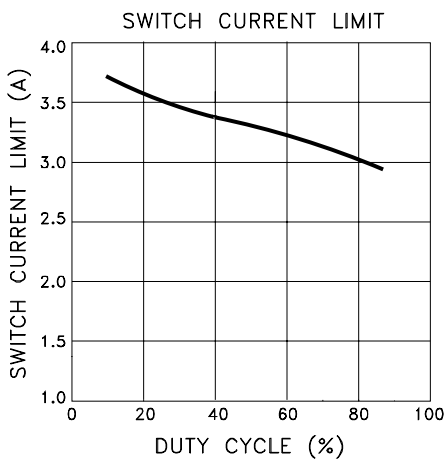
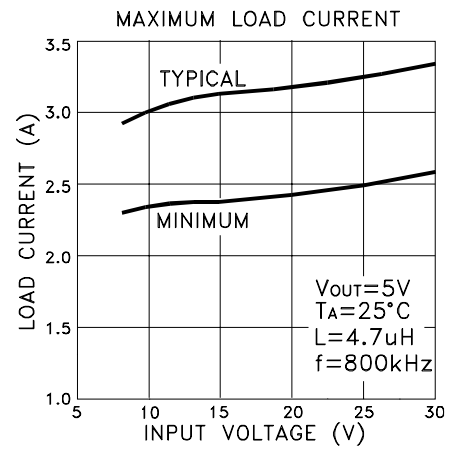
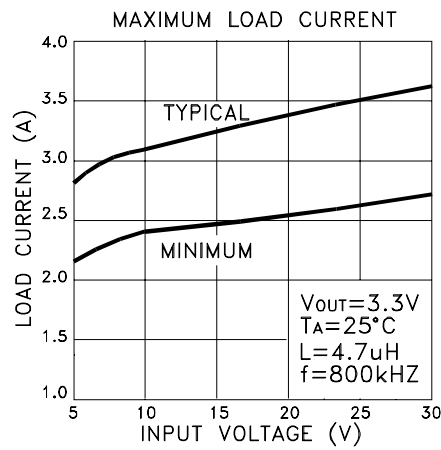
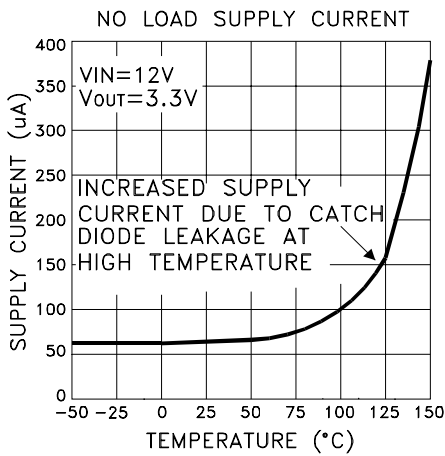
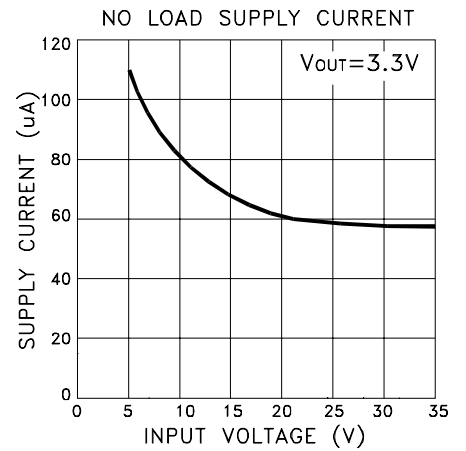
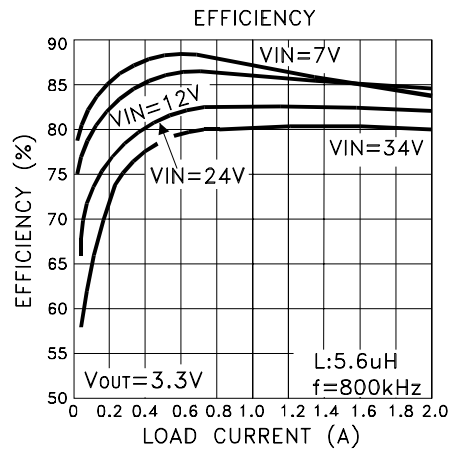
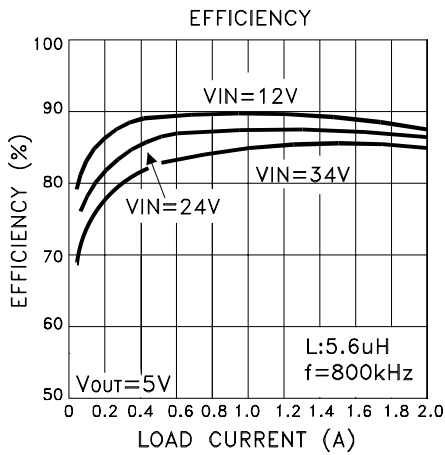

TYPICAL PERFORMANCE CURVES CONT'D

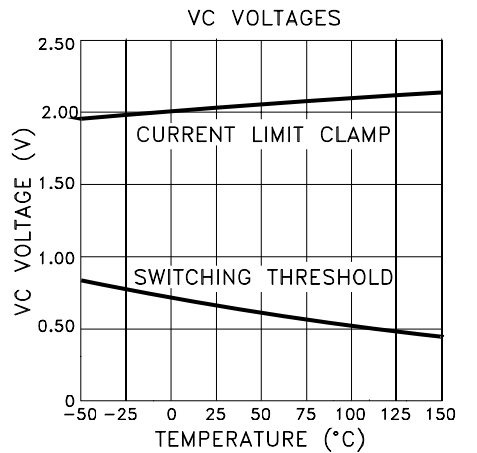
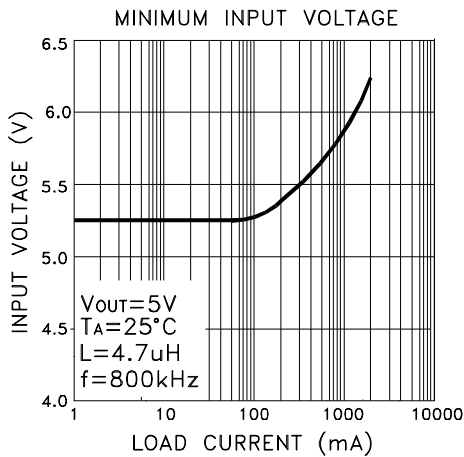
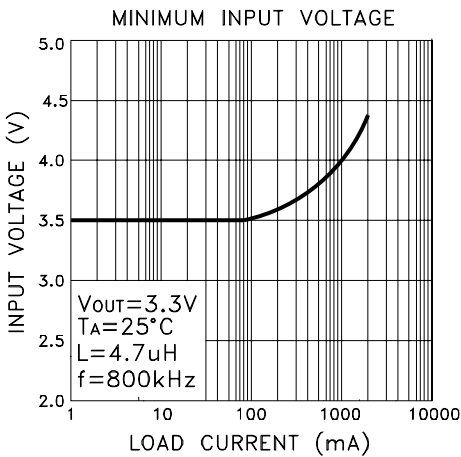
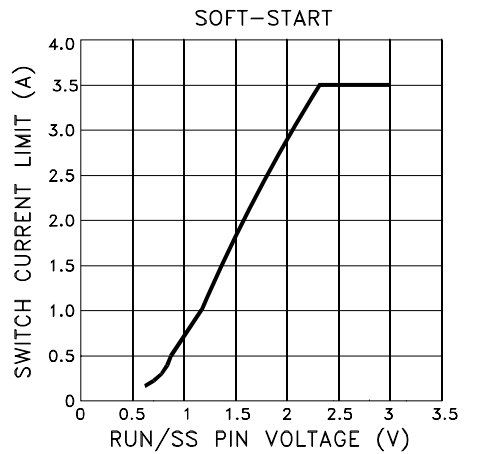
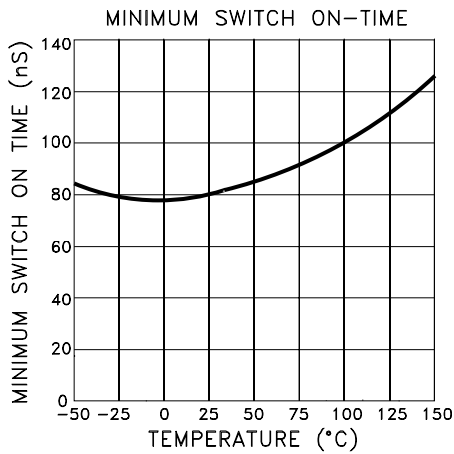
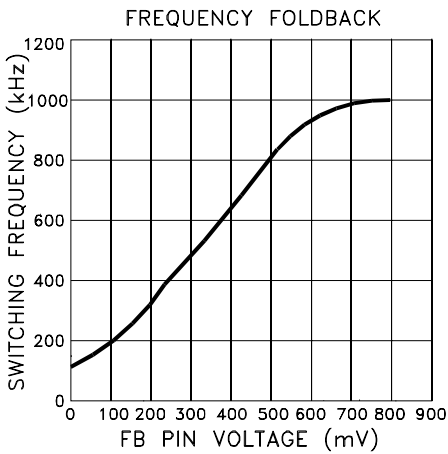
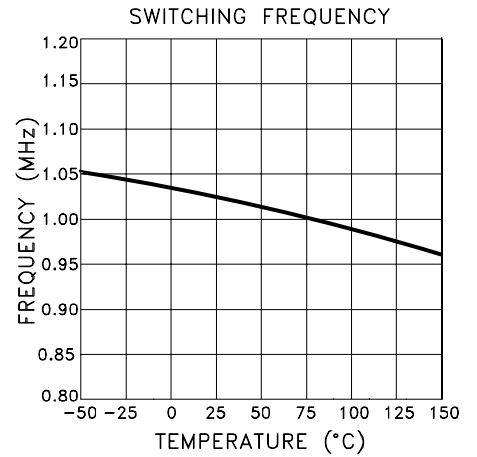
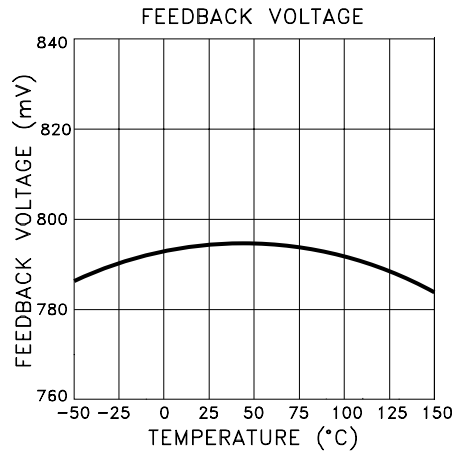
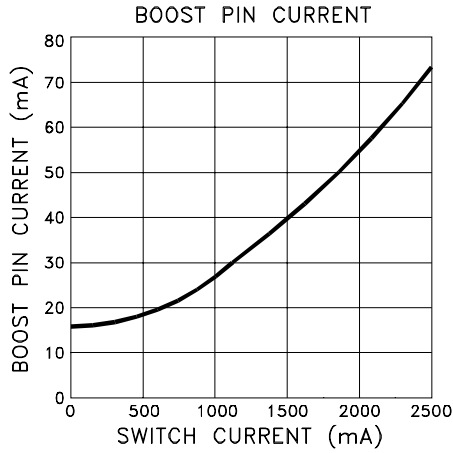

MECHANICAL SPECIFICATIONS

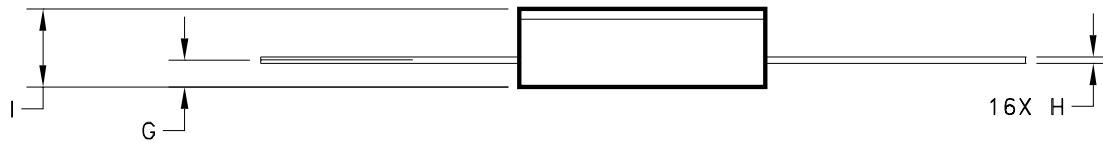
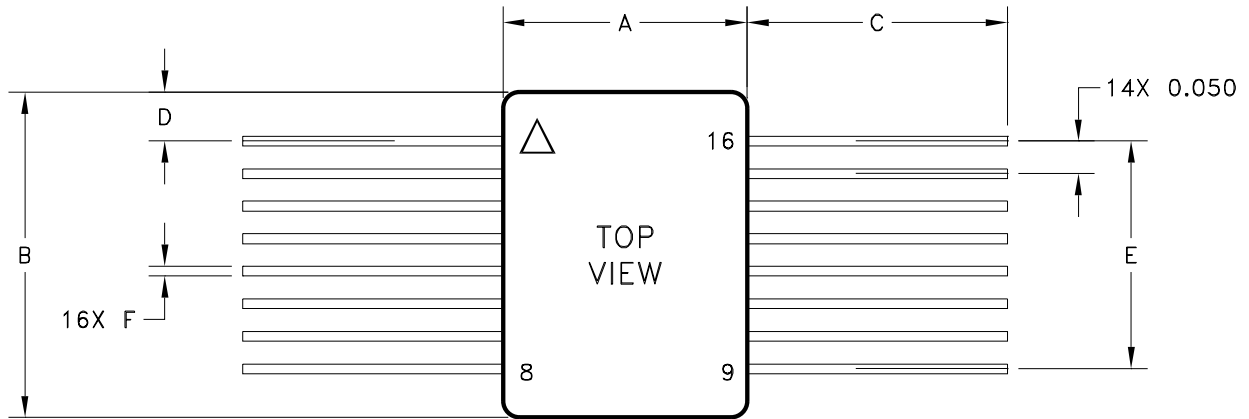

REF	MIN	MAX
A	0.365	0.385
B	0.490	0.510
C	0.400	—
D	0.075 REF	
E	0.345	0.355
F	0.012	0.018
G	0.032	0.052
H	0.008	0.012
I	—	0.115

ESD TRIANGLE INDICATES PIN 1
WEIGHT=1.5 GRAMS TYPICAL

ALL DIMENSIONS ARE SPECIFIED IN INCHES

ORDERING INFORMATION

PART NUMBER	SCREENING LEVEL	LEADS
MSK5031	INDUSTRIAL	STRAIGHT
MSK5031H	MIL-PRF-38534 CLASS H	

MECHANICAL SPECIFICATIONS

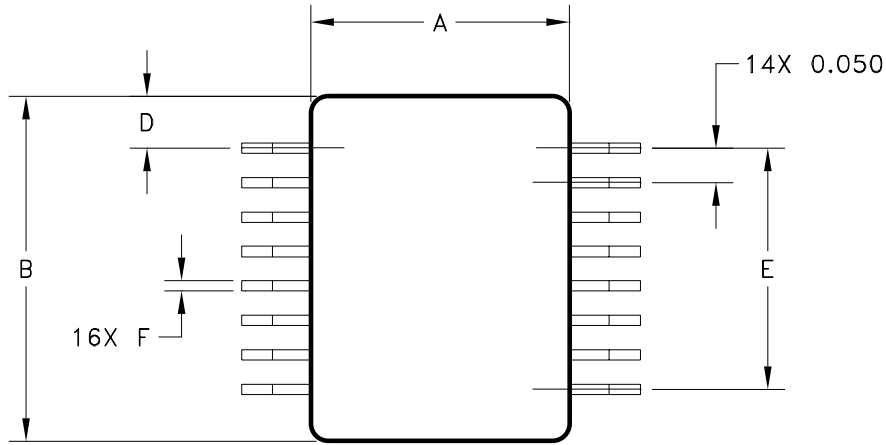

REF	MIN	MAX
A	0.365	0.385
B	0.490	0.510
C	0.045	0.055
D	0.075 REF	
E	0.345	0.355
F	0.012	0.018
G	0.050 REF	
H	0.008	0.012
I	—	0.115
J	0.008	0.018
K	0.550	0.600

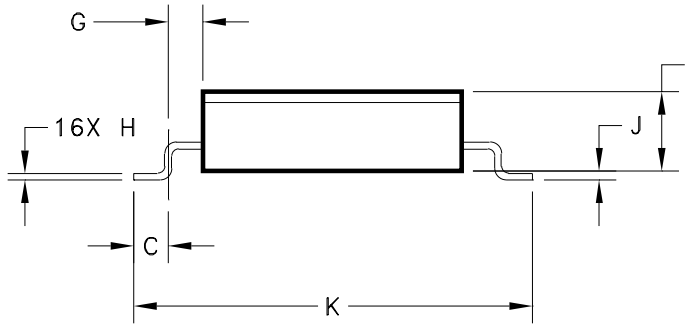

NOTE: "J" IS MEASURED FROM
BOTTOM OF PIN TO
BOTTOM OF CASE

ESD TRIANGLE INDICATES PIN 1
WEIGHT=1.5 GRAMS TYPICAL

ALL DIMENSIONS ARE SPECIFIED IN INCHES

ORDERING INFORMATION

PART NUMBER	SCREENING LEVEL	LEADS
MSK5031G	INDUSTRIAL	GULL WING
MSK5031HG	MIL-PRF-38534 CLASS H	

REVISION HISTORY

REV	STATUS	DATE	DESCRIPTION
E	Released	01/15	Add internal note and clarify mechanical outline specifications.

MSK
www.anaren.com/msk

The information contained herein is believed to be accurate at the time of printing. MSK reserves the right to make changes to its products or specifications without notice, however, and assumes no liability for the use of its products. Please visit our website for the most recent revision of this datasheet.
Contact MSK for MIL-PRF-38534 qualification status.