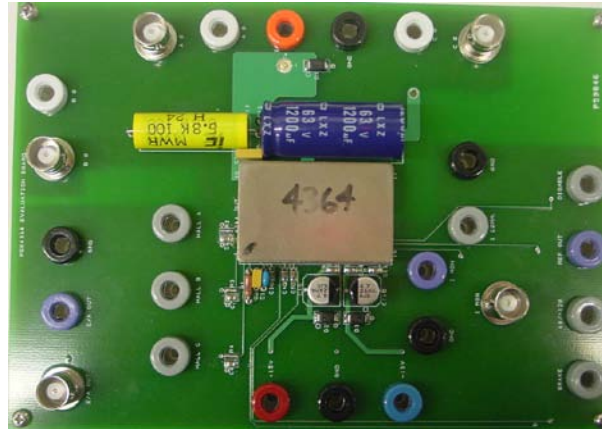

MSK4364 Evaluation Board User's Guide

By Bob Abel & Dan Williams, MS Kennedy Corp.; Revised 9/19/2013

**Introduction**

The MSK 4364 is a complete 3 Phase MOSFET Bridge Brushless Motor Control System in an electrically isolated hermetic package. The hybrid is capable of 5 amps of output current and 55 volts of DC bus voltage. It has the normal features for protecting the bridge. Included is all the bridge drive circuitry, hall sensing circuitry, commutation circuitry and all the current sensing and analog circuitry necessary for closed loop current mode (torque) control. When PWM'ing, the transistors are modulated in locked anti-phase mode for the tightest control and the most bandwidth. Provisions for applying different compensation schemes are included. The MSK 4364 has good thermal conductivity of the MOSFET's due to isolated substrate/package design that allows direct heat sinking of the hybrid without insulators.

This configuration can be used to control a variety of loads, such as a brushed DC motor or a voice coil. Because of the internal PWM generator, all the user needs to do is provide an analog voltage representative of the PWM duty cycle desired on the output.

The evaluation board provides a platform from which to evaluate new designs with ample real estate to make changes and evaluate results. Evaluation early in the design phase reduces the likelihood of excess ripple, instability, or other issues, from becoming a problem at the application PCB level.

This application note is intended to be used in conjunction with the MSK4364 data sheet. Reference the device data sheet for additional application information and specifications.

Setup

Use the standard 4mm banana jacks to interface with the assembly to connect to your power supply and motor assembly. Use the BNC interface connections for monitoring the phases, and for your analog input for setting the speed and direction.

Design Details

Device Block Diagram

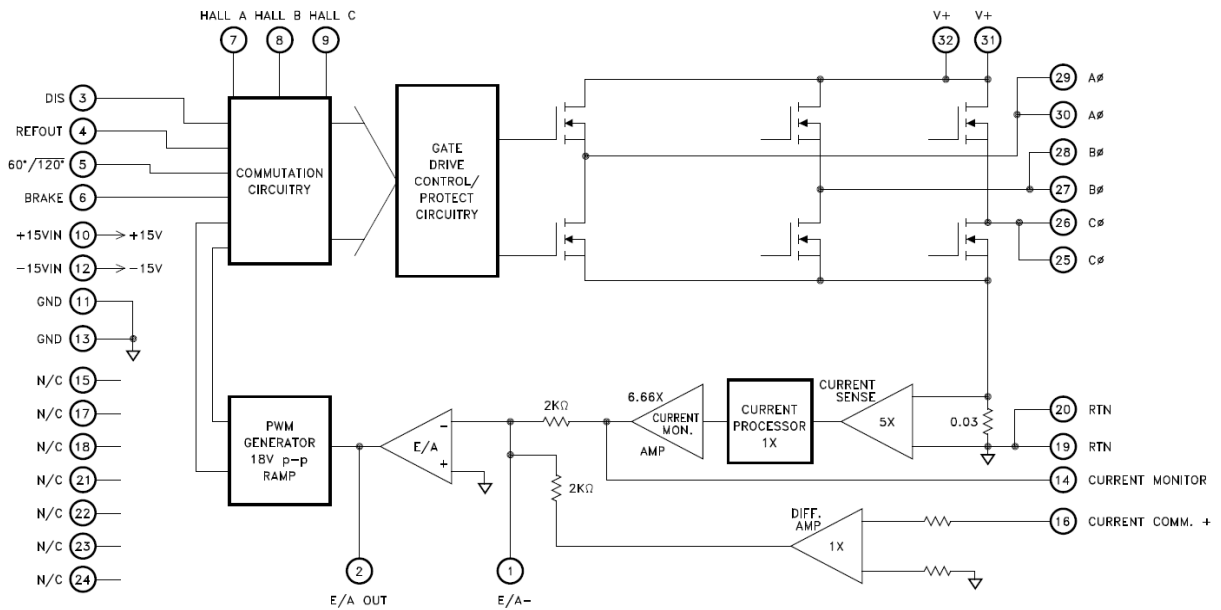

PCB Artwork

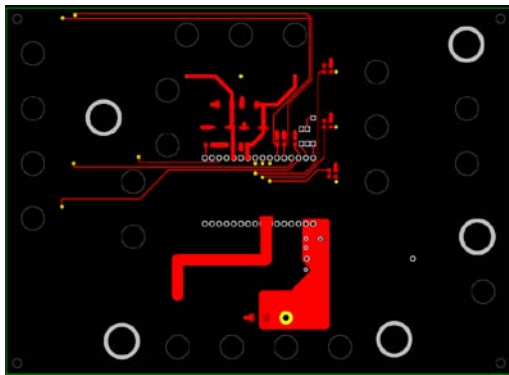

Top Side

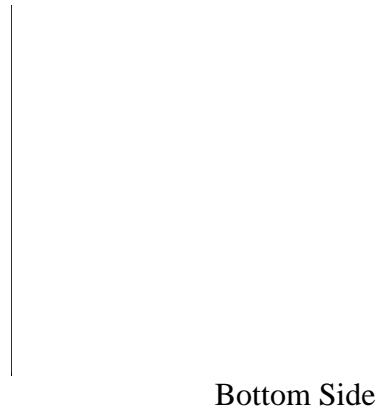

Bottom Side

Schematic

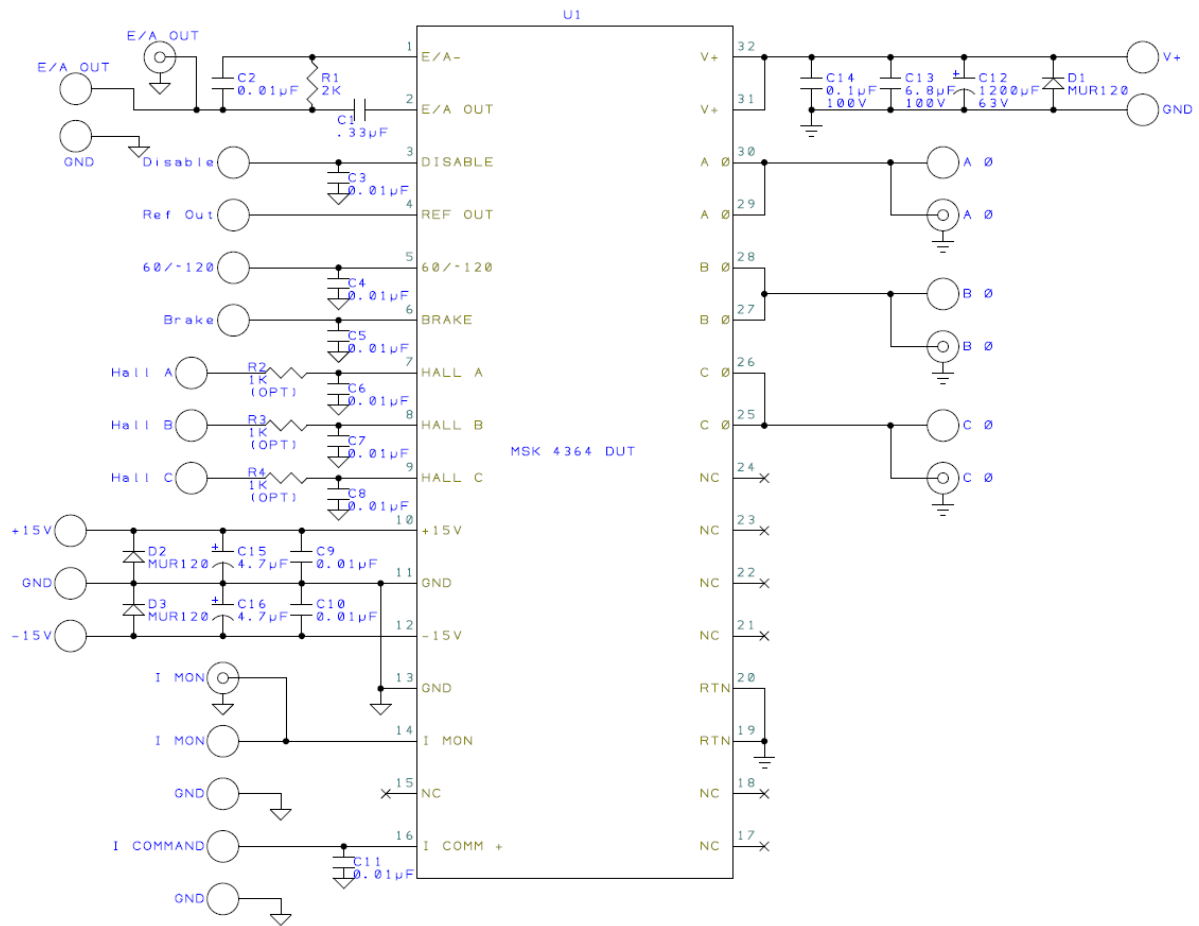

Bill of Materials

Ref Des/Qty	Value	Manufacturer	P/N
R2-R4	OPTIONAL		
R1	2K (VARIABLE)		
C1	0.33 μ F (VARIABLE)		
C2	0.01 μ F (VARIABLE)		
C15, C16	4.7 μ F	Panasonic Electronics	EEE-HA2A4R7P
C3-C11	0.01 μ F	Panasonic Electronics	ECJ-2VB1H103K
C14	0.1 μ F, 100V	AVX CORP	CK06BX104K
C13	6.8 μ F, 100V	ILLINOIS CAPACITOR	685MWR100K
C12	1200 μ F, 63V	United Chemi-Con	ELXZ630ELL122ML40S
D1, D2, D3	MUR120	ON Semiconductor	MUR120T3G
21	BANANA JACKS	EMERSON/JOHNSON	108-09XX-001
5	BNC'S	TE Connectivity	1-1337542-0
48	.015/.025 dia. pin recept.	MILL MAX	0677-0-15-01-30-27-10-0
16	.022/.032 dia. pin recept.	MILL MAX	0295-0-15-01-06-27-10-0
4	7/8", #4, STANDOFFS		
4	3/8", #4, SCREWS		
1	MSK 4364	MSK	
1	MSK 4364 EVAL BOARD	ADVANCED CIRCUITS	