



# 10 AMP, 200V, 3 PHASE MOSFET BRUSHLESS MOTOR CONTROLLER

# 4324

### FEATURES:

- 200 Volt Motor Supply Voltage
- 10 Amp Output Switch Capability
- Shoot-Through/Cross Conduction Protection
- Hall Sensing and Commutation Circuitry on Board
- "Real" Four Quadrant Torque Control Capability
- Good Accuracy Around the Null Torque Point
- Hermetic Package Design for High Voltage Isolation Plus Good Thermal Transfer
- 60°/ 120° Phasing Selectable
- Contact MSK for MIL-PRF-38534 Qualification Status

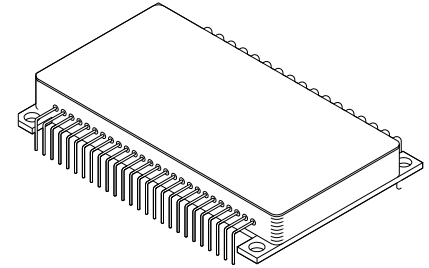

### DESCRIPTION:

The MSK4324 is a complete 3 Phase MOSFET Bridge Brushless Motor Control System in a convenient isolated baseplate package. The device is capable of 10 amps of output current and 200 volts of DC bus voltage. It has the normal features for protecting the bridge. Included is all the bridge drive circuitry, hall sensing circuitry, commutation circuitry and all the current sensing and analog circuitry necessary for closed loop current mode (torque) control. When PWM'ing, the transistors are modulated in locked anti-phase (complementary) mode for the tightest control and the most bandwidth. Provisions for applying different compensation schemes are included. The MSK4324 has good thermal conductivity of the MOSFET's due to a hermetic isolated package design that allows direct heat sinking of the device without insulators.

### BLOCK DIAGRAM

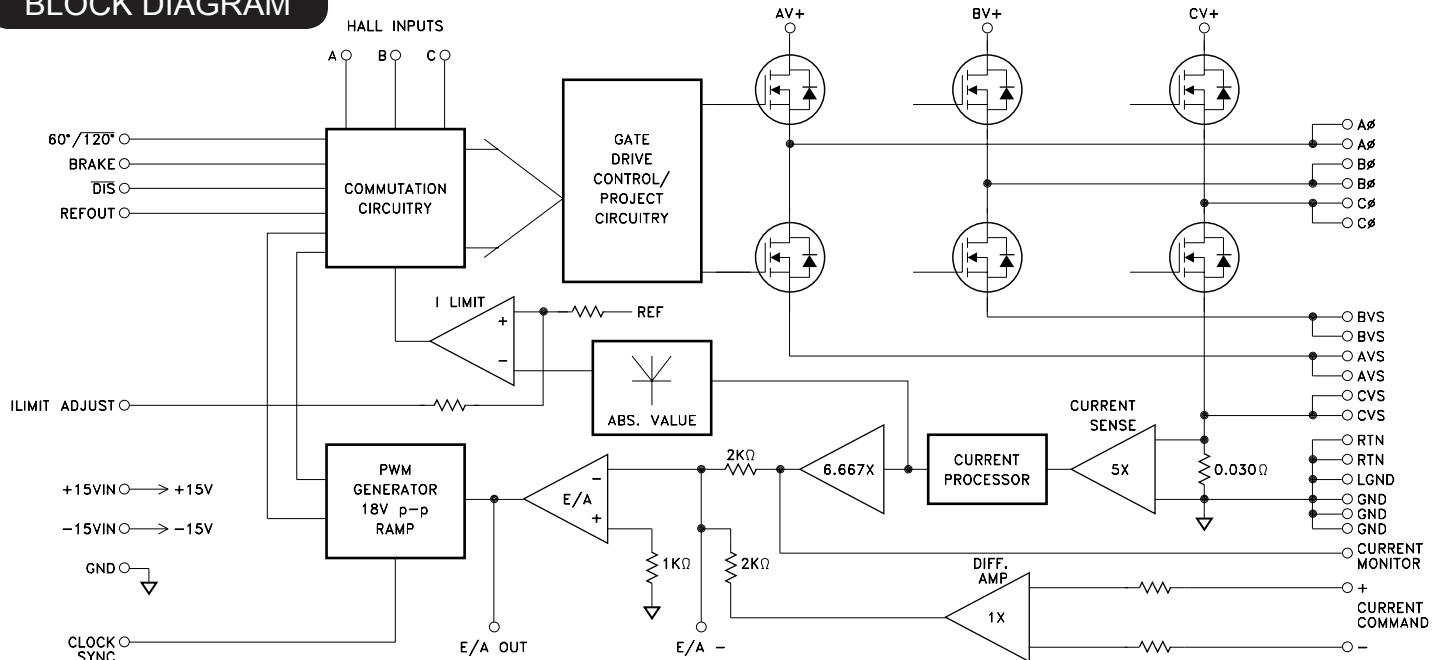

### TYPICAL APPLICATIONS

- 3 Phase Brushless DC Motor Control
- Servo Control
- Fin Actuator Control
- Gimbal Control
- AZ-EL Control

### PIN-OUT INFORMATION

1	REFOUT	12	E/A OUT	23	GND	34	BVS
2	HALL A	13	E/A-	24	NC	35	BVS
3	HALL B	14	GND	25	NC	36	BØ
4	HALL C	15	+CURRENT COMMAND	26	LGND	37	BØ
5	60°/120°	16	-CURRENT COMMAND	27	RTN	38	BV+
6	BRAKE	17	+15 VIN	28	RTN	39	AVS
7	CLOCK SYNC	18	CURRENT MONITOR	29	CVS	40	AVS
8	DIS	19	-15 VIN	30	CVS	41	AØ
9	GND	20	NC	31	CØ	42	AØ
10	NC	21	NC	32	CØ	43	AV+
11	NC	22	ILIMIT ADJUST	33	CV+		

# ABSOLUTE MAXIMUM RATINGS <sup>⑦</sup>

High Voltage Supply <sup>⑨</sup> .....	200V
Current Command Input.....	+13.5V
Logic Inputs.....	-0.2V to REFOUT
REFOUT External Load.....	15 mA
E/A OUT External Load.....	5 mA
Clock SYNC Input.....	-0.2V to +15V
Continuous Output Current.....	10 Amps
Continuous Output Current @ 125°C Case.....	5 Amps
Peak Output Current.....	15 Amps

R <sub>θJC</sub> Thermal Resistance (Output Switches@125°C)	0.5°C/W
T <sub>ST</sub> Storage Temperature Range <sup>⑩</sup> .....	-65°C to +150°C
T <sub>LD</sub> Lead Temperature Range (10 Seconds).....	+300°C
T <sub>C</sub> Case Operating Temperature MSK4324.....	-40°C to +85°C
MSK4324H.....	-55°C to +125°C
T <sub>J</sub> Junction Temperature.....	+150°C

# ELECTRICAL SPECIFICATIONS

Parameter	Test Conditions	Group A Subgroup <sup>④ ⑤</sup>	MSK4324H <sup>⑤</sup>			MSK4324 <sup>②</sup>			Units
			Min.	Typ.	Max.	Min.	Typ.	Max.	
<b>INPUT CURRENT</b>									
+15 VIN	Output PWM'ing Current Command=0 Volts	1	-	89	150	-	89	150	mA
		2	-	83	150	-	-	-	mA
		3	-	106	150	-	-	-	mA
-15 VIN	Output PWM'ing Current Command=0 Volts	1	-	24	60	-	24	60	mA
		2	-	26	60	-	-	-	mA
		3	-	23	60	-	-	-	mA
PWM Clock Frequency	Free Running	4	14	17	20	14	17	20	KHz
		5,6	14	17	20	-	-	-	KHz
<b>CLOCK SYNC INPUT</b>									
V <sub>IL</sub> <sup>①</sup>		-	-	-	2.5	-	-	2.5	V
V <sub>IH</sub> <sup>①</sup>		-	12.5	-	-	12.5	-	-	V
Duty Cycle <sup>①</sup>		-	10	-	90	10	-	90	%
Sync Frequency <sup>①</sup>		-	Clock+0	-	Clock+3	Clock+0	-	Clock+3	KHz
<b>LOGIC INPUTS (Hall A,B,C,Brake,60°/120°)</b>									
V <sub>IL</sub> <sup>①</sup>		-	-	-	0.8	-	-	0.8	V
V <sub>IH</sub> <sup>①</sup>		-	3.0	-	-	3.0	-	-	V
<b>DIS</b>									
V <sub>IL</sub> <sup>①</sup>		-	-	-	2.5	-	-	2.5	V
V <sub>IH</sub> <sup>①</sup>		-	12.5	-	-	12.5	-	-	V
<b>REFERENCE</b>	@ 15mA Load	1	5.82	6.25	6.57	5.82	6.25	6.57	V
<b>ANALOG SECTION</b>									
Current Command Input Range <sup>①</sup>		-	-13.5	-	+13.5	-13.5	-	+13.5	V
Current Command Input Current <sup>①</sup>		-	-	-	1.5	-	-	1.5	mA
Transconductance <sup>⑥</sup>		4	0.90	1.0	1.1	0.85	1.0	1.15	A/V
		5,6	0.85	1.0	1.15	-	-	-	A/V
Offset Current	Current Command=0 Volts	1	-25	0	+25	-50	0	+50	mA
Current Monitor <sup>⑥</sup>		4	0.90	1.0	1.1	0.85	1.0	1.15	V/A
		5,6	0.85	1.0	1.15	-	-	-	V/A
Current Motor Voltage Swing		-	-12	-	+12	-12	-	+12	V
Error Amp	@ 5mA Load								
E/A OUT Voltage Swing <sup>①</sup>		-	-12	-	+12	-12	-	+12	V
Slew Rate <sup>①</sup>	@ 5mA Load	-	6.8	8	-	6.8	8	-	V/μsec
Gain Bandwidth Product <sup>①</sup>		-	-	6.5	-	-	6.5	-	MHz
Large Signal Voltage Swing <sup>①</sup>		-	175	275	-	175	275	-	V/mV
Current Limit Adjust	Pin 22 1.92KΩ to GND	1	4	5	6	4	5	6	Amps
<b>OUTPUT SECTION</b>									
Voltage Drop Across Bridge (1 Upper & 1 Lower) <sup>①</sup>	5 Amps @ 125°C T <sub>c</sub>	-	-	-	TBD	-	-	TBD	V
		-	-	-	TBD	-	-	-	V
Leakage Current <sup>①</sup>	Whole Bridge	-	-	-	1	-	-	1	mA
T <sub>RR</sub> <sup>①</sup>	All Switches off, 100V,150°C	-	-	220	330	-	220	330	nsec
Dead Time <sup>①</sup>		-	-	3	-	-	3	-	μsec
Drain-Source On Resistance <sup>① ⑧</sup>	@ 5 Amps, 150°C Junction	-	-	-	0.151	-	-	0.151	Ω

## NOTES:

- ① Guaranteed by design but not tested. Typical parameters are representative of actual device performance but are for reference only.
- ② Industrial grade devices shall be tested to subgroups 1 and 4 unless otherwise specified.
- ③ Military grade devices ("H" suffix) shall be 100% tested to subgroups 1,2,3 and 4.
- ④ Subgroups 5 and 6 testing available upon request.
- ⑤ Subgroup 1,4 TA=TC=+25°C  
2,5 TA=TC=+125°C  
3,6 TA=TC=-55°C
- ⑥ Measurements do not include offset current at 0V current command.
- ⑦ Continuous operation at or above absolute maximum ratings may adversely effect the device performance and/or life cycle.
- ⑧ This is to be used for MOSET thermal calculations only.
- ⑨ When applying power to the device, apply the low voltage followed by the high voltage or alternatively, apply both at the same time. Do not apply high voltage without low voltage present.
- ⑩ Internal solder reflow temperature is 180°C, do not exceed.

## MSK4324 PIN DESCRIPTIONS

**AV+, BV+, CV+** - are the power connections from the hybrid to the bus. The pins for each phase are brought out separately and must be connected together to the V+ source externally. The external wiring to these pins should be sized according to the RMS current required by the motor. These pins should be bypassed by a high quality monolithic ceramic capacitor for high frequencies and enough bulk capacitance for keeping the V+ supply from drooping.

Note: this is a power sequence sensitive part. Either turn on all supplies simultaneously or provide  $\pm 15V$  first, then V+ voltages.

**AØ, BØ & CØ** - are the connections to the motor phase windings from the bridge output. The wiring to these pins should be sized according to the current required by the motor. There are no short circuit provisions for these outputs. Shorts to V+ or ground from these pins must be avoided or the bridge will be destroyed.

**AVS, BVS, CVS** - are the return pins on the bottom of each half bridge. They are brought out separately and should be connected together externally to allow the current from each half bridge to flow through the sense resistor. The wiring on these pins should be sized according to the current requirements of the motor.

**RTN** - is the power return connection from the module to the bus. All ground returns connect to this point from internal to the module in a star fashion. All external ground connections to this point should also be made in a similar fashion. The V+ capacitors should be returned to this pin as close as possible. Wire sizing to this pin connection should be made according to the required current.

**LGND** - is an isolated ground connection to the RTN pin of the hybrid that is connected internally. For any circuitry that needs to be connected to the RTN pin without the influence of current flow through RTN should be connected at this point.

**GND** - is a ground pin that connects to the ground plane for all low powered circuitry inside the hybrid.

**+15 VIN** - is the input for applying +15 volts to run the low power section of the hybrid. This pin should be bypassed with a 10  $\mu F$  capacitor and a 0.1  $\mu F$  capacitor as close to this pin as possible.

Note: this is a power sequence sensitive part. Either turn on all supplies simultaneously or provide  $\pm 15V$  first, then V+ voltages.

**-15 VIN** - is the input for applying -15 volts to run the low power section of the hybrid. This pin should be bypassed with a 10  $\mu F$  capacitor and a 0.1  $\mu F$  capacitor as close to this pin as possible.

Note: this is a power sequence sensitive part. Either turn on all supplies simultaneously or provide  $\pm 15V$  first, then V+ voltages.

**CURRENT COMMAND (+,-)** - are differential inputs for controlling the module in current mode. Scaled at  $\pm 1$  amp per volt of input command, the bipolar input allows both forward and reverse current control capability regardless of motor commutation direction. The maximum operational command voltage should be  $\pm 10$  volts for  $\pm 10$  amps of motor current.

**CURRENT MONITOR** - is a pin providing a current viewing signal for external monitoring purposes. This is scaled at  $\pm 1$  amp of motor current per volt output, up to a maximum of  $\pm 10$  volts, or  $\pm 10$  amps. As  $\pm 10$  amps is exceeded, the peaks of the waveform may become clipped as the rails of the amplifiers are reached. This voltage is typically  $\pm 12.5$  volts, equating to  $\pm 12.5$  amps of current peaks. In DIS mode, the CURRENT MONITOR output may rail positive or negative, depending on internal bias currents. When re-enabled, this output will resume expected operation.

**E/A OUT** - is the current loop error amp output connection. It is brought out for allowing various loop compensation circuits to be connected between this and E/A-. See "anti-windup" discussion later on in this section.

**E/A-** - is the current loop error amp inverting input connection. It is brought out for allowing various loop compensation circuits to be connected between this and E/A OUT. See "anti-windup" discussion later on in this section.

**CLOCK SYNC** - is an input for synchronizing to an external clock. The sync circuit will trigger on the edges of the applied clock and effectively shorten the period of the internal oscillator on each cycle. The frequency can be increased from a free running 14 KHz to 20 KHz maximum. The clock applied shall be 15 volts amplitude with at least a 10% duty cycle.

**REFOUT** - is a 6.25 volt regulated output to be used for powering the hall devices in various motors. Up to 15 mA of output current is available.

**HALL A, B & C** - are the hall input pins from the hall devices in the motor. These pins are internally pulled up to 6.25 volts. The halls can reflect a 120/240 degree commutation scheme or a 60/300 degree scheme.

**BRAKE** - is a pin for commanding the output bridge into a motor BRAKE mode. When pulled low, normal operation commences. When pulled high, the 3 high side bridge switches turn off and the 3 low side bridge switches turn on, causing rapid deceleration of the motor and will cease motor operation until pulled high again. Logic levels for this input are TTL compatible. It is necessary to toggle ON and OFF BRAKE after power up before normal operation can begin. This is necessary because of the bootstrap high-side power supplies for each phase. These are not continuous high-side supplies and need to be refreshed by turning on the low side switches momentarily with the BRAKE. It is internally pulled high.

**DIS** - is a pin for externally disabling the output bridge. A 15V CMOS logic high will enable the bridge and a 15V CMOS logic low will disable it. After using the DIS pin, the BRAKE must be cycled ON and OFF before normal operation will begin. This is due to the bootstrap high-side supplies needing refreshing.

**60/120** - is a pin for selecting the orientation of the commutation scheme of the motor. A high state will produce 60/300 degree commutation, whereas a low state will produce 120/240 degree commutation. Logic levels for this input are TTL compatible. It is internally pulled high.

**ILIMIT ADJUST** - is a pin for externally adjusting the current limit point. By placing a resistor to ground from this pin, a voltage divider is created and the current limit will be lowered. Without an external resistor, the current limit is set at 13 Amps.

# APPLICATION NOTES CONTINUED

## COMMUTATION TRUTH TABLE

HALL SENSOR PHASING						I <sub>COMMAND</sub> = POS.			I <sub>COMMAND</sub> = NEG.			BRAKE
120°			60°			AØ	BØ	CØ	AØ	BØ	CØ	
HALL A	HALL B	HALL C	HALL A	HALL B	HALL C	AØ	BØ	CØ	AØ	BØ	CØ	
1	0	0	1	0	0	H	-	L	L	-	H	0
1	1	0	1	1	0	-	H	L	-	L	H	0
0	1	0	1	1	1	L	H	-	H	L	-	0
0	1	1	0	1	1	L	-	H	H	-	L	0
0	0	1	0	0	1	-	L	H	-	H	L	0
1	0	1	0	0	0	H	L	-	L	H	-	0
1	1	1	1	0	1	-	-	-	-	-	-	0
0	0	0	0	1	0	-	-	-	-	-	-	0
X	X	X	X	X	X	L	L	L	L	L	L	1

1 = High Level  
 0 = Low Level  
 X = Don't Care

H = SOURCE  
 L = SINK  
 - = OPEN

**NOTE:** Because of the true 4 quadrant method of output switching, the output switches will PWM between the I<sub>COMMAND</sub> POSITIVE and I<sub>COMMAND</sub> NEGATIVE states, with the average percentage based on I<sub>COMMAND</sub> being a positive voltage and a negative voltage. With a zero voltage I<sub>COMMAND</sub>, the output switches will modulate with exactly a 50% duty cycle between the I<sub>COMMAND</sub> POSITIVE and I<sub>COMMAND</sub> NEGATIVE states.

### EXTERNAL CURRENT LIMIT RESISTOR SELECTION CHART

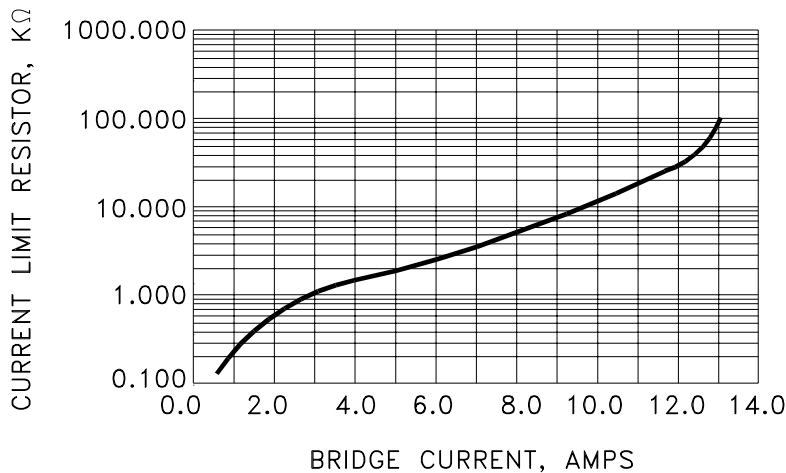

CURRENT (A)	RESISTOR (KΩ)
2.0	0.56
4.0	1.37
6.0	2.61
8.0	4.77
10.0	9.48

## APPLICATION NOTES CONTINUED

### BUS VOLTAGE FILTER CAPACITORS

The size and placement of the capacitors for the DC bus has a direct bearing on the amount of noise filtered and also on the size and duration of the voltage spikes seen by the bridge. What is being created is a series RLC tuned circuit with a resonant frequency that is seen as a damped ringing every time one of the transistors switches. For the resistance, wire resistance, power supply impedance and capacitor ESR all add up for the equivalent lumped resistance in the circuit. The inductance can be figured at about 30 nH per inch from the power supply. Any voltage spikes are on top of the bus voltage and the back EMF from the motor. All this must be taken into account when designing and laying out the system. If everything has been minimized, there is another solution. A second capacitance between 5 and 10 times the first capacitor and it should either have some ESR or a resistor can be added in series with the second capacitor to help damp the voltage spikes.

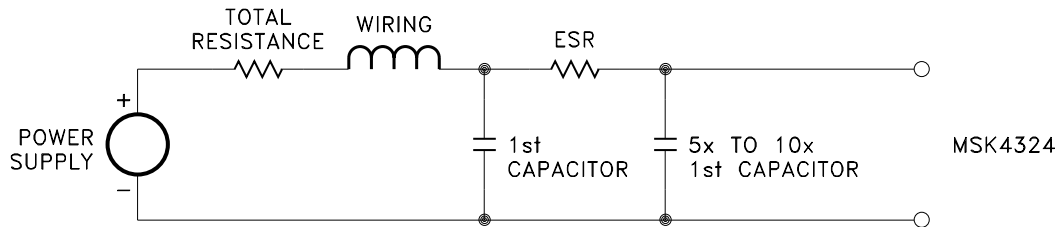

Be careful of the ripple current in all the capacitors. Excessive ripple current, beyond what the capacitors can handle, will destroy the capacitors.

### REGULATED VOLTAGE FILTER CAPACITORS

It is recommended that about 10  $\mu\text{F}$  of capacitance (tantalum) for bypassing the + and -15V regulated outputs be placed as close to the module pins as practical. Adding ceramic bypass capacitors of about 0.1  $\mu\text{F}$  or 1  $\mu\text{F}$  will aid in suppressing noise transients.

### GENERAL LAYOUT

Good PC layout techniques are a must. Ground planes for the analog circuitry must be used and should be tied back to the small pin grounds 9, 14 and 23. Additional ground, pin 26 is an isolated ground that connects internally directly back to the main DC bus ground pin 27, 28. This can be used as necessary for voltage sensing, etc.

### LOW POWER STARTUP

When starting up a system utilizing the MSK4324 for the first time, there are a few things to keep in mind. First, because of the small size of the module, short circuiting the output phases either to ground or the DC bus will destroy the bridge. The current limiting and control only works for current actually flowing through the bridge. The current sense resistor has to see the current in order for the electronics to control it. If possible, for startup use a lower voltage and lower current power supply to test out connections and the low current stability. With a limited current supply, even if the controller locks up, the dissipation will be limited.

### COMPENSATION AND ANTI-WINDUP

By observing the E/A OUT pin which is the error amp output, much can be found out about the health and stability of the system. An even waveform with some rounded triangle wave should be observed. As current goes up, the DC component of the waveform should move up or down. At full current (with a regular supply) the waveform should not exceed +8 volts positive peak, or -8 volts negative peak. Some audible noise will be heard which will be the commutation frequency. If the motor squeals, there is instability and power should be removed immediately unless power dissipation isn't excessive due to limited supply current. For compensation calculations, refer to the block diagram for all information to determine the amplifier gain for loop gain calculations.

Because this high voltage torque amplifier contains only high-side bootstrap supplies, it must continuously PWM the bridge to refresh the high-side supply capacitors. Additionally, this type of amplifier controls the loop through PWM, so it must PWM all of the time in order to maintain control.

When the bridge commutates the motor through each phasing state, the current path switches windings. The current must be ramped back up after each transition. With an integrating compensation scheme, it is very possible for the error amplifier to exceed the PWM maximum and minimum voltages. When this happens, the loop stops PWM control and the error amplifier will continue to integrate and ramp up to the voltage rail. This is called integrator windup.

Recovery from integrator windup can take a significant amount of time, long enough for the bootstrap supply capacitors to be depleted and shut off the gate drive. This must be prevented from happening. By placing zener diode clamps across the error amplifier output to the inverting input, it will clamp the amplifier from running past the PWM maximum and minimum.

For a free-running clock with no synchronization, the zeners used should be 7.5V. In each direction, the voltage will be 7.5V plus one diode drop, or 8.2V to 8.5V. If the synchronization pin is being used for clock sync, then that voltage may have to be lower, as the sync scheme effectively shortens up the PWM ramp to increase frequency and sync clock. A 100 ohm series current limiting resistor is necessary to prevent the error amplifier from driving too much current back through the feedback when the diodes are conducting.

# MSK4370 TEST CIRCUIT

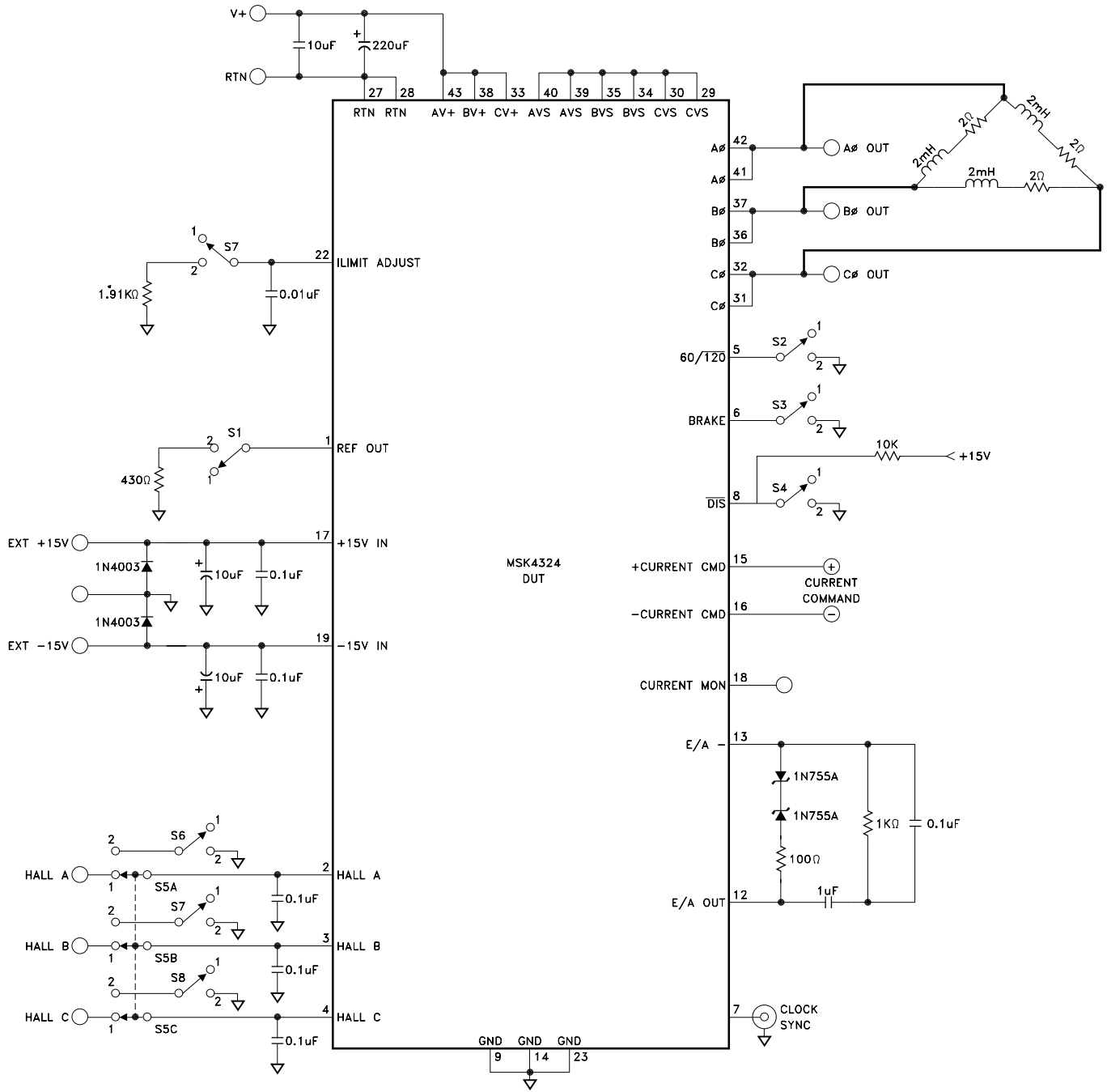

TYPICAL TEST SCHEMATIC

# MECHANICAL SPECIFICATIONS

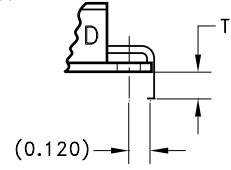
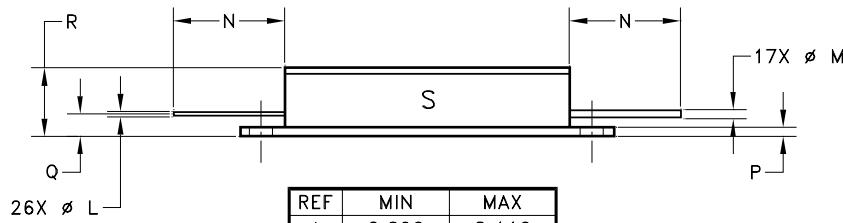
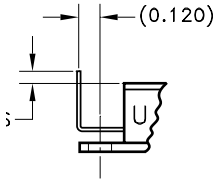
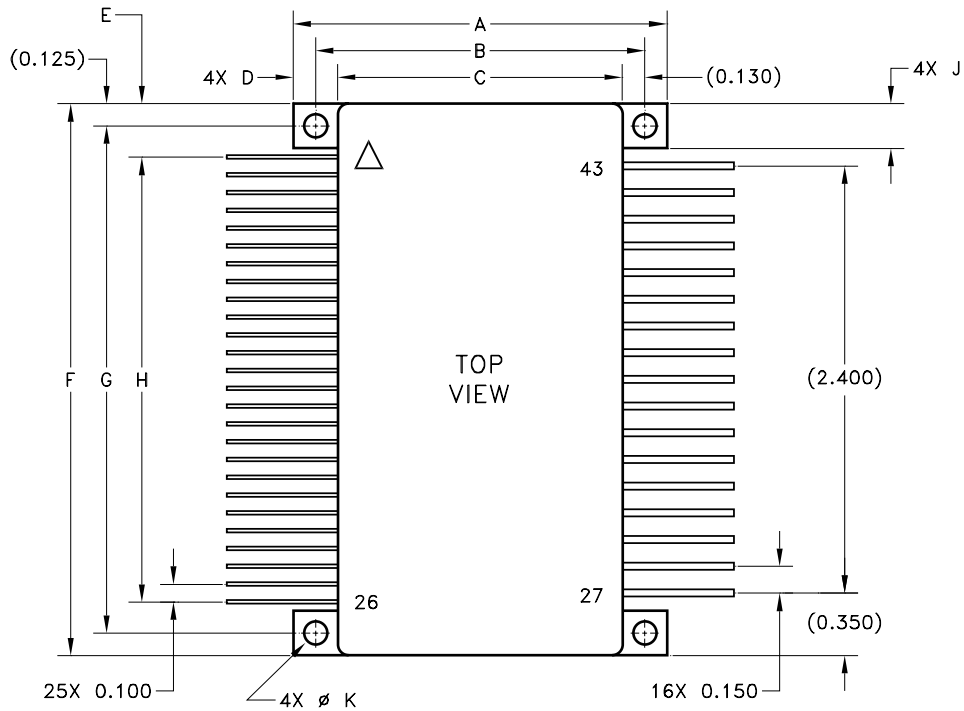

REF	MIN	MAX
A	2.090	2.110
B	1.850	1.870
C	1.590	1.610
D	0.245	0.255
E	0.290	0.310
F	3.090	3.110
G	2.840	2.860
H	2.490	2.510
J	0.245	0.255
K	0.123	0.132
L	0.018	0.022
M	0.038	0.042
N	0.600	
P	0.045	0.055
Q	0.165	0.185
R		0.395
S	0.175	
T	0.250	

ESD TRIANGLE INDICATES PIN 1  
WEIGHT = 88 GRAMS TYPICAL

ALL DIMENSIONS ARE SPECIFIED IN INCHES

## ORDERING INFORMATION

**MSK4324 H U**

**LEAD CONFIGURATION**

S=STRAIGHT, U=BENT UP, D=BENT DOWN

**SCREENING**

BLANK=INDUSTRIAL; H=MIL-PRF-38534 CLASS H

**GENERAL PART NUMBER**

THE ABOVE EXAMPLE IS A MILITARY GRADE DEVICE WITH LEADS BENT UP.

## REVISION HISTORY

REV	STATUS	DATE	DESCRIPTION
G	Released	01/15	Add internal note and clarify mechanical specifications.

MSK  
[www.anaren.com/msk](http://www.anaren.com/msk)

---

The information contained herein is believed to be accurate at the time of printing. MSK reserves the right to make changes to its products or specifications without notice, however, and assumes no liability for the use of its products. Please visit our website for the most recent revision of this datasheet.  
Contact MSK for MIL-PRF-38534 qualification status.