



## MSK4310 Demonstration

By Dan Williams, MS Kennedy Corp.; Revised 9/19/2013

### Introduction

---

The MSK4310 3 Phase DC Brushless Speed Controller hybrid is a complete closed loop velocity mode controller for driving a brushless motor. It requires no external velocity feedback devices for operation. Feedback is derived from the hall signal outputs from the motor.

In velocity control, velocity sensing from the motor is used to create a feedback to signal the controller to either speed up or slow down the motor to match the speed input signal in a control loop. The feedback signal and the input signal are fed into an error amplifier. The output signal of the error amplifier will then supply the proper information to a pulse width modulator (PWM), which will chop the DC supply voltage to the motor. This chopped DC voltage will cause the motor to respond as though it were a smooth, proportional DC voltage that will either speed up, slow down or maintain a set speed, regardless of the load on the motor.

This application note will describe a demonstration motor controller circuit and motor, utilizing a MSK4310 Speed Controller. The method used to determine the components for setting up the loop will be shown. Waveforms from the Demonstration Board will also be shown.

### Discussion

---

Referring to the schematic, the MSK4310 is shown, complete with all the necessary bypassing of the +/-15V INPUT to SIGNAL GROUND and V+ to GND for the motor supply voltage. In this demonstration, +28V was used for the motor supply voltage. Connected to the TACH OUT are two op amps used to convert the TACH OUT pulses into a smooth variable output voltage, ANALOG TACH OUTPUT. This output can be used to observe the actual motor speed response and will help determine the correct feedback components used for the desired response, and will be shown here.

The motor used for the experiment is a Kollmorgen RBE(H) 01210 motor. The motor is a 100 watt motor with a Back EMF Constant of 3.43 V/KRPM. At 28 volts DC input, the motor should turn approximately 8000 RPM, no load. This number will be needed for setting up the TACH R/C network on the MSK4310.

The MSK4310 generates a TACH OUT pulse based on every high and low transition of each of the three hall input signals from the motor. As the motor speeds up, the repetition rate goes up. The output is a constant pulse, variable frequency signal. An 8-pole motor will go through 4 “electrical” rotation sequences for every physical revolution of the output

shaft, with each electrical rotation consisting of one complete 360 degree commutation sequence. Every hall output from the motor will transition to ON and OFF once per 360 degree electrical commutation. All 3 halls together will create 6 transitions, which when multiplied times 4 electrical rotations, gives a total of 24 transitions in 1 physical revolution of the motor shaft. At 8000 RPM, there will be 192,000 transitions per minute, or 3200 transitions per second. This is the basis for setting up the pulse width of the TACH OUT.

$$\begin{aligned}
 & \mathbf{8000 \text{ Shaft Revolutions per Minute}} \\
 & \mathbf{x (8 \text{ poles}/2=4 \text{ electrical rotations per Revolution})} \\
 & \mathbf{x (2 \text{ Transitions per hall})} \\
 & \mathbf{x 3 \text{ halls}} \\
 & \mathbf{/ 60 \text{ seconds per minute} =} \\
 & \mathbf{\underline{3200 \text{ transitions per second (at full speed)}}}
 \end{aligned}$$

Selection of the resistor and capacitor for the TACH R/C that determines the TACH OUT pulse is as follows: At 3200 transitions per second, full speed, the period is 312.5 $\mu$ Sec. To make sure that the pulse width isn't larger than the pulse period, the desired pulse width was chosen to be 300 $\mu$ Sec. The capacitor  $C_T$  was selected to be 0.01 $\mu$ F and the resistor  $R_T$ , 28.44K $\Omega$ . The TACH OUT pulse width roughly correlates to  $T=RC$ . The graph in Figure 1 in the data sheet is good for an approximation, and final values were chosen from testing. Having the pulse width overlap the period before full speed is reached would cause the feedback loop to lose control. It is desired to have a good, proportional signal coming from the TACH OUT all the way up to full speed, at which time the speed controller is no longer modulating the motor output voltage. This will allow full loop control all the way to full motor speed.

The error amplifier has the "absolute value" speed command connected to the non-inverting input, and the TACH OUT network output is brought into the inverting input. On the Demonstrator Board, the feedback network is a resistive proportional feedback with a parallel integrator capacitor to give a roll-off at a desired frequency, depending on the needs of the system. The following describes the set up of the error amplifier.

The maximum output of the error amplifier to the PWM input is 4.1V. Anything beyond this voltage will be beyond the PWM range. On the Demonstrator Board, a maximum SPEED COMMAND voltage of 4.1V is used. The DC gain equation for the error amplifier is:

$$\mathbf{TACH \text{ OUT} \times (-R_f / R_i) + \mathbf{SPEED \text{ COMMAND} \times (1+R_f / R_i) = 4.1V}$$

The TACH OUT at maximum RPM will be the maximum voltage of the TACH OUT x the duty cycle of the pulse train for an average voltage to be applied to the error amplifier:

$$\begin{aligned}
 & \mathbf{4.1V \text{ (the maximum voltage of the TACH OUT pulse train)}} \\
 & \mathbf{x 300\mu\text{Sec (TACH RC pulse width) / 312.5\mu\text{Sec (period of the TACH OUT}} \\
 & \mathbf{\text{pulse train at maximum RPM) = 3.936V}}
 \end{aligned}$$

Solve for  $R_f / R_i$ ,

**Error amplifier DC Gain = 4**

100K $\Omega$  was chosen for  $R_f$  to allow for a reasonably sized integrator capacitor to tailor the response of the system; therefore,  $R_i = 25K\Omega$ .

The current limit adjustment resistor (I LIM ADJ) is the last value that needs to be determined. A 5 amp limit was selected. See Figure 2 in the data sheet for current limit component selection. For a 5 amp limit, a 3k $\Omega$  resistor from the I LIM ADJ pin to ground will produce a 5 amp peak current limit. At this point, the circuit is ready for initial checkout.

Connect the motor with the correct hall inputs and output phasing. Evaluation of the circuit can then begin. The  $V_+$  voltage was set to 28 volts, and a variable DC source voltage was input to SPEED COMMAND inputs. An input voltage of about 0.33V will just get the motor turning with no load. Increasing the DC voltage up to a maximum of about 4.1V into SPEED COMMAND increases the speed of the motor. At about 4.1V, the output stage of the MSK4310 has reached maximum voltage (maximum duty cycle of 100%) to the motor and there is no more modulation of the output drive. The maximum speed of the motor is about 7600RPM. Checking on the output of the error amplifier will confirm that its output has gone past the maximum PWM input voltage of 4.1V. Going higher than 4.1V won't make any difference because the peak input on the other side of the comparator (the sawtooth) for the PWM generator peaks at 4.1V.

The circuit developed for the Demonstrator Board includes an averaging circuit for the TACH OUT pulses, giving a DC representation of the pulses for use with determining the mechanical response of the system – see Figures 1 and 2. The output of the ANALOG TACH OUT is scaled to match the average voltage created by the TACH OUT pulses.

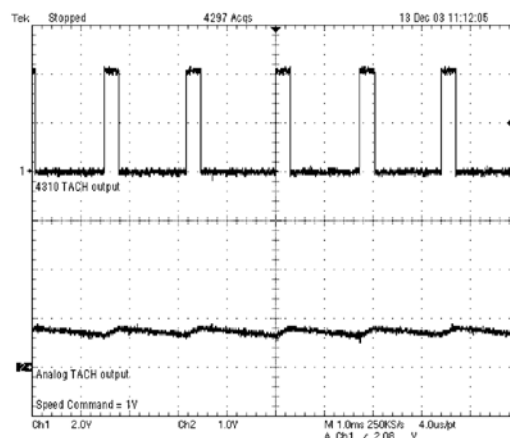

**Figure 1**

Pulse train output from TACH OUT and the voltage waveform output from the ANALOG TACH OUT for a 1V input to SPEED COMMAND

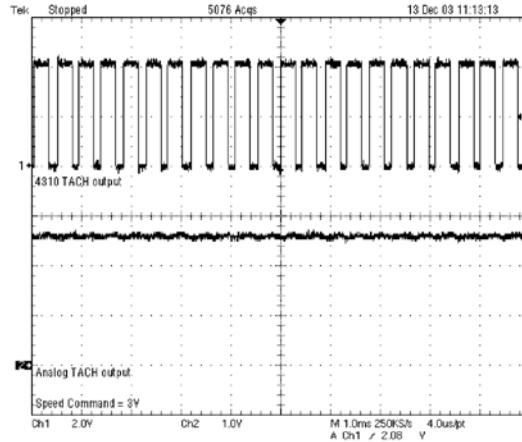
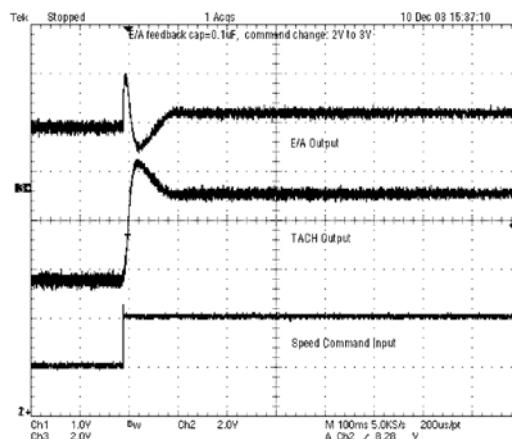

**Figure 2**

Pulse train output from TACH OUT and the voltage waveform output from the ANALOG TACH OUT for a 3V input to SPEED COMMAND

Viewing the ANALOG TACH OUT while inputting various stimuli, whether it is a step command voltage or an AC sine wave, will allow tailoring the response of the integrator in the error amplifier for the desired response of the motor in the system. Comparing the input frequency of the SPEED COMMAND to the ANALOG TACH OUT frequency will allow bandwidth measurements to be made.

To view this in action, a step change in the SPEED COMMAND was set up. For the input, a 1V step on top of a 2V offset was used. The 2V signal will make sure that the controller is running well in closed loop control. The 1V step on top of the 2V will cause a step change in speed to be initiated throughout the system. The response of the error amplifier and the response from the motor itself could then be observed for various feedback capacitance values as shown in Figures 3a-c.



**Figure 3a**

1V Step response with a 0.1 $\mu$ F capacitor for the error amplifier feedback

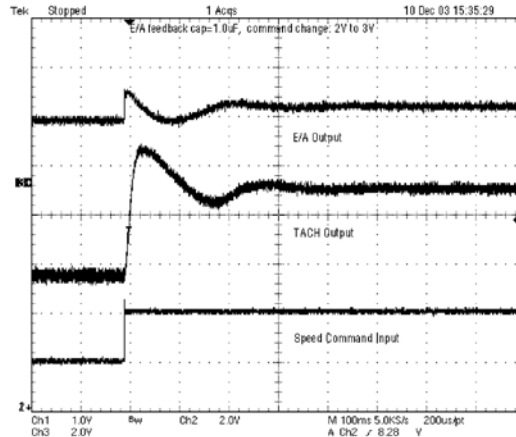

**Figure 3b**

1V Step response with a 1.0 $\mu$ F capacitor for the error amplifier feedback

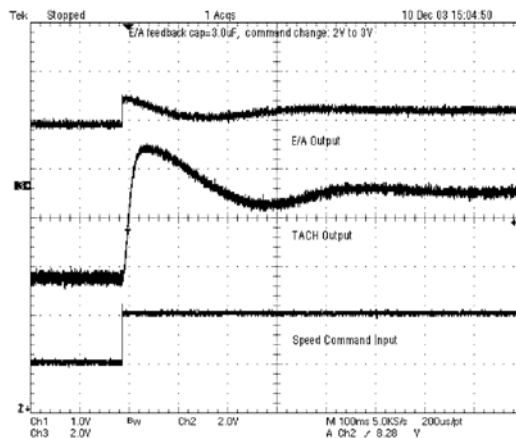
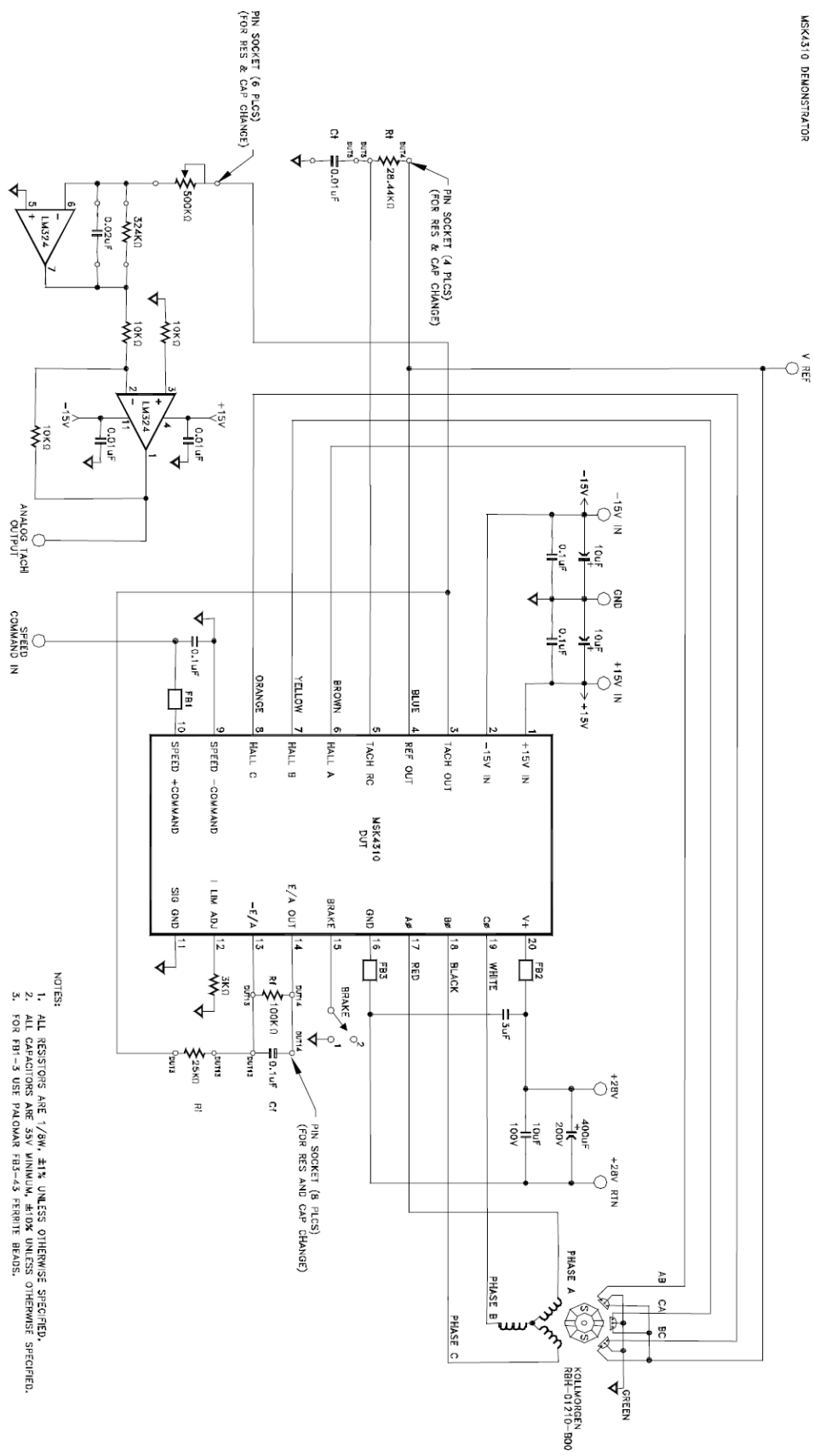

**Figure 3c**

1V Step response with a 3.0 $\mu$ F capacitor for the error amplifier feedback

It can be observed that by changing the feedback capacitor in the error amplifier integrator circuit, various responses to step changes can be incorporated into the overall system. Bear in mind that for this experiment, there was no load on the motor, only inertia from the mass of the rotor. As the rotor shaft gets loaded, the mechanical response to the step input will change. For a system application, the response will have to be adjusted for the required output for the application. Such tests are beyond the scope of this demonstration.

This demonstrates the closed loop speed control capabilities of the MSK4310. It has been shown with the Demonstrator Board that the MSK4310 is an effective closed loop brushless DC motor speed controller by using the hall sensor signals as a form of tachometer. This hall-derived tachometer will allow a high performance speed control to be established for a system. The response of the system can be tailored to the desired performance required. The MSK4310 can be used to solve a speed control problem without the need to add an expensive motor shaft tachometer to close the speed loop.



- NOTES:
1. ALL RESISTORS ARE 1/8W, ±1% UNLESS OTHERWISE SPECIFIED.
  2. ALL CAPACITORS ARE 35V MINIMUM, ±10% UNLESS OTHERWISE SPECIFIED.
  3. FOR FB1-3 USE PALOMAR FB3-43 FERRITE BEADS.