



M.S.KENNEDY CORP.

# 10 AMP, 75V, H-BRIDGE MOSFET BRUSHED MOTOR CONTROLLER

# 4251

4707 Dey Road Liverpool, N.Y. 13088

(315) 701-6751

**FEATURES:**

- 75 Volt Motor Supply Voltage
- 10 Amp Output Switch Capability
- 100% Duty Cycle High Side Conduction Capable
- Shoot-Through/Cross Conduction Protection
- "Real" Four Quadrant Torque Control Capability
- Good Accuracy Around the Null Torque Point
- Non-Hermetic Isolated Package

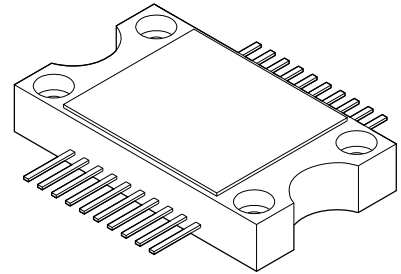

**DESCRIPTION:**

The MSK 4251 is a complete H-bridge MOSFET Brushed Motor Control System in an electrically isolated plastic encapsulated package. The hybrid is capable of 10 amps of output current and 75 volts of DC bus voltage. It has the normal features for protecting the bridge. Included is all the bridge drive circuitry, and all the current sensing and analog circuitry necessary for closed loop current mode (torque) control. When PWM'ing, the transistors are modulated in locked anti-phase mode for the tightest control and the most bandwidth. Provisions for applying different compensation schemes are included. The MSK 4251 has good thermal conductivity of the MOSFET's due to the electrically isolated substrate/package design that allows direct heat sinking of the hybrid without insulators.

**EQUIVALENT SCHEMATIC**

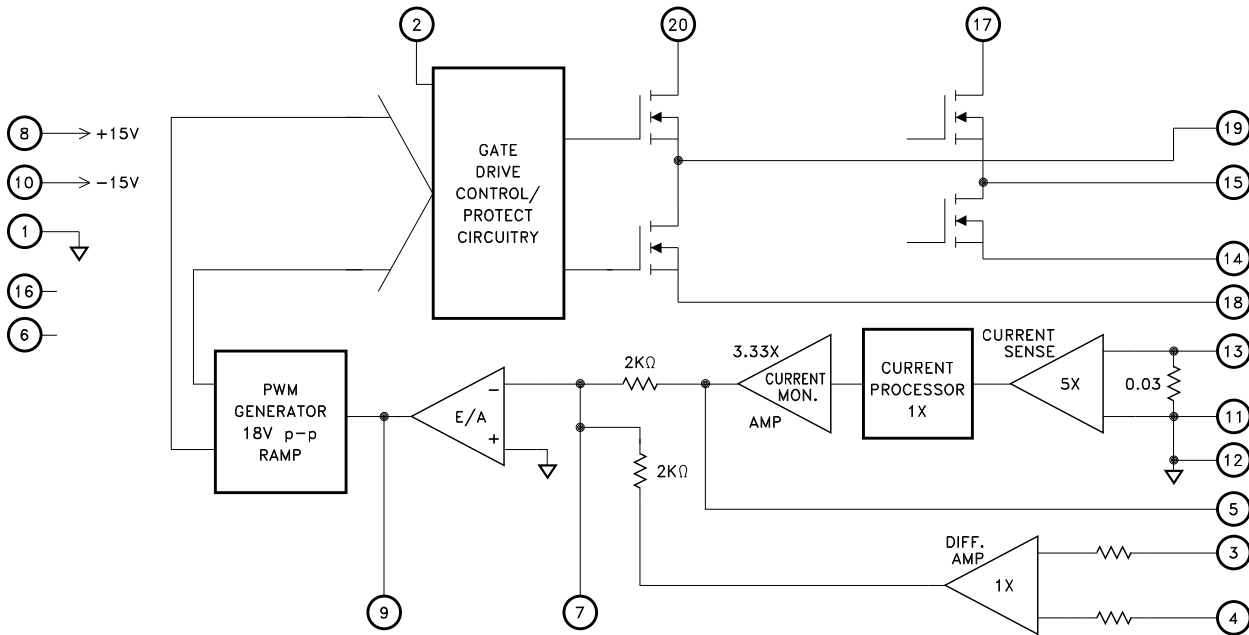

**TYPICAL APPLICATIONS**

- Brushed DC Motor Control
- Servo Control
- Fin Actuator Control
- Voice Coil Control
- Gimbal Control
- AZ-EL Control

**PIN-OUT INFORMATION**

1 GND	20 AV +
2 DISABLE	19 AØ
3 CURRENT COMM. +	18 AV-
4 CURRENT COMM.-	17 BV +
5 CURRENT MONITOR	16 NC
6 NC	15 BØ
7 E/A-	14 BV-
8 +15VIN	13 SENSE RESISTOR +
9 E/A OUT	12 RTN
10 -15VIN	11 RTN

## ABSOLUTE MAXIMUM RATINGS <sup>⑤</sup>

V <sub>+</sub>	High Voltage Supply <sup>⑥</sup>	75V
V <sub>IN</sub>	Current Command Input	±13.5V
+V <sub>CC</sub>		+16V
-V <sub>CC</sub>		-18V
I <sub>OUT</sub>	Continuous Output Current	10A
I <sub>PK</sub>	Peak Output Current	20A

θ <sub>JC</sub>	Thermal Resistance @ 125°C	3.0°C/W
T <sub>ST</sub>	Storage Temperature Range	-40°C to +150°C
T <sub>LD</sub>	Lead Temperature Range (10 Seconds)	+300°C
T <sub>C</sub>	Case Operating Temperature MSK4251	-40°C to +85°C
T <sub>J</sub>	Junction Temperature	+150°C

## ELECTRICAL SPECIFICATIONS

All Ratings: T<sub>c</sub> = +25°C Unless Otherwise Specified

Parameter	Test Conditions <sup>②</sup>	MSK 4251			Units
		Min.	Typ.	Max.	
<b>POWER SUPPLY REQUIREMENTS</b>					
+V <sub>CC</sub>	@ +15V	-	70	85	mA
-V <sub>CC</sub>	@ -15V	-	17	35	mA
<b>PWM</b>					
Free Running Frequency		22	25	28	KHz
<b>CONTROL</b>					
Transconductance <sup>④</sup>	±10 Amps Output	1.8	2	2.2	Amp/Volt
Current Monitor <sup>④</sup>	±10 Amps Output	0.425	0.5	0.575	V/Amp
Output Offset	@ 0 Volts Command	-	±5.0	±35.0	mAmp
<b>ERROR AMP</b>					
Input Voltage Range <sup>①</sup>		±11	±12	-	Volts
Slew Rate <sup>①</sup>		6.5	8	-	V/μSec
Output Voltage Swing <sup>①</sup>		±12	±13	-	Volts
Gain Bandwidth Product <sup>①</sup>		-	6.5	-	MHz
Large Signal Voltage Gain <sup>①</sup>		175	275	-	V/mV
<b>OUTPUT</b>					
Rise Time <sup>①</sup>		-	100	-	nSec
Fall Time <sup>①</sup>		-	100	-	nSec
Leakage Current <sup>①</sup>	@ 64V, +150°C Junction	-	-	750	μAmps
Voltage Drop Across Bridge (1 Upper and 1 Lower) <sup>①</sup>	@ 10 Amps	-	-	0.3	Volts
Voltage Drop Across Bridge (1 Upper and 1 Lower) <sup>①</sup>	@10Amps, +150°C Junction	-	-	0.6	Volts
Drain-Source On Resistance (Each MOSFET) <sup>③①</sup>	@ 10 Amps, 150°C Junction	-	-	0.026	Ω
Diode VSD <sup>①</sup>	@ 10 Amps, Each FET	-	-	2.6	Volts
T <sub>RR</sub> <sup>①</sup>	IF = 10 Amps, di/dt = 100A/μS	-	280	-	nSec
Dead Time <sup>①</sup>		-	2	-	μSec

### NOTES:

- ① Guaranteed by design but not tested. Typical parameters are representative of actual device performance but are for reference only.
- ② ±V<sub>CC</sub> = +15V, V<sub>+</sub> = 28V unless otherwise specified.
- ③ This is to be used for MOSFET thermal calculation only.
- ④ Measurements do not include offset current at 0V current command.
- ⑤ Continuous operation at or above absolute maximum ratings may adversely effect the device performance and/or life cycle.
- ⑥ When applying power to the device, apply the low voltage followed by the high voltage or alternatively, apply both at the same time. Do not apply high voltage without low voltage present.

## APPLICATION NOTES

### MSK 4251 PIN DESCRIPTIONS

**AV+, BV+** - are the power connections from the hybrid to the bus. All pins for the motor voltage supply should be connected together to share the current through the pins in the hybrid. The external wiring to these pins should be sized according to the RMS current required by the motor. A high quality monolithic ceramic capacitor for high frequencies and enough bulk capacitance for keeping the V+ supply from drooping should bypass these pins. 1000 $\mu$ F is recommended. Capacitors should be placed as close to these pins as practical.

**A $\emptyset$ , B $\emptyset$**  - are the connections to the motor phase windings from the bridge output. The wiring to these pins should be sized according to the required current by the motor. There are no short circuit provisions for these outputs. Shorts to V+ or ground from these pins must be avoided or the bridge will be destroyed. All pins for each phase should be connected together to share the current through the three pins in the hybrid.

**RTN** - is the power return connection from the module to the bus. All internal ground returns connect to this point inside the hybrid. All three pins should be connected together to share the current. All capacitors from the V+ bus should connect to this point as close as possible. All external V+ return connections should be made as close to these pins as possible. Wiring sizing to this pin should be made according to the required current.

**GND** - is the return point for the low powered circuitry inside the hybrid. All GND pins should be tied together. All capacitors for bypassing the + and -15V supplies should be tied at this point, as close to the pins as possible. Any ground plane connections for low powered and analog circuitry outside the hybrid should be tied to this point.

**+15VIN** - is the input for applying +15 volts to run the low power section of the hybrid. Both pins should be used together for optimum operation. These pins should be bypassed with a 10 $\mu$ F capacitor and a 0.1 $\mu$ F capacitor as close to these pins as possible.

**-15VIN** - is the input for applying -15 volts to run the low power section of the hybrid. Both pins should be used together for optimum operation. These pins should be bypassed with a 10 $\mu$ F capacitor and a 0.1 $\mu$ F capacitor as close to these pins as possible.

**SENSE RESISTOR +** - is the top of the sense resistor for sensing the bridge current and closing the loop. The bottom of the sense resistor is RTN. All the AV- and BV- pins should be connected to this point.

**AV-,BV-** - are the power pins for the bottom of the bridge. These are to be connected to sense resistor +.

**DISABLE** - is a pin for externally disabling the output bridge. A TTL logic low will enable the bridge and a TTL high will disable it. It is internally pulled up by a 100 $\mu$ Amp pull-up.

**CURRENT COMMAND (+,-)** - are differential inputs for controlling the module in current mode. Scaled at 2 amps per volt of input command, the bipolar input allows both forward and reverse current control capability regardless of motor commutation direction. The maximum operational command voltage should be  $\pm 5$  volts for  $\pm 10$  amps of motor current. Going beyond 5 volts of command voltage will force the bridge to conduct more than the desired maximum current. There is internal current limiting that will ultimately limit the absolute maximum current being output by the bridge.

**CURRENT MONITOR-** is a pin providing a current viewing signal for external monitoring purposes. This is scaled at  $\pm 2$  amps of motor current per volt output, up to a maximum of  $\pm 5$  volts, or  $\pm 10$  amps. Going beyond the 5 volt maximum may result in clipping of the waveform peaks. In DISABLE mode, the CURRENT MONITOR output may rail positive or negative, depending on internal bias currents. When re-enabled, this output will resume expected operation.

**E/A OUT** - is the current loop error amplifier output. It is brought out for allowing various loop compensation circuits to be connected between this and E/A-.

**E/A-** - is the current loop error amplifier inverting input. It is brought out for allowing various loop compensation circuits to be connected between this and E/A OUT.

**BUS VOLTAGE FILTER CAPACITORS**

The size and placement of the capacitors for the DC bus has a direct bearing on the amount of noise filtered and also on the size and duration of the voltage spikes seen by the bridge. What is being created is a series RLC tuned circuit with a resonant frequency that is seen as a damped ringing every time one of the transistors switches. For the resistance, wire resistance, power supply impedance and capacitor ESR all add up for the equivalent lumped resistance in the circuit. The inductance can be figured at about 30nH per inch from the power supply. Any voltage spikes are on top of the bus voltage and the back EMF from the motor. All this must be taken into account when designing and laying out the system. If everything has been minimized, there is another solution. A second capacitance between 5 and 10 times the first capacitor and it should either have some ESR or a resistor can be added in series with the second capacitor to help damp the voltage spikes.

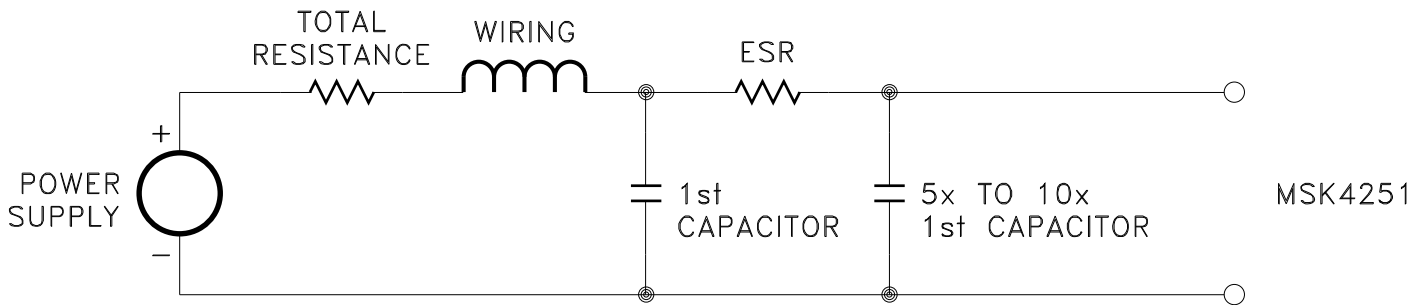

Be careful of the ripple current in all the capacitors. Excessive ripple current, beyond what the capacitors can handle, will destroy the capacitors.

**± 15VIN FILTER CAPACITORS**

It is recommended that about 10  $\mu$ F of capacitance (tantalum electrolytic) for bypassing the + and -15V inputs be placed as close to the module pins as practical. Adding ceramic bypass capacitors of about 0.1  $\mu$ F or 1  $\mu$ F will aid in suppressing noise transients.

**GENERAL LAYOUT**

Good PC layout techniques are important. Ground planes for the analog circuitry must be used and should be tied back to the small signal grounds, pin 1. The high power grounds (RTN) pins 11 and 12 get tied back to the small signal ground internally. DO NOT connect these grounds externally. A ground loop will result.

**LOW POWER STARTUP**

When starting up a system utilizing the MSK 4251 for the first time, there are a few things to keep in mind. First, because of the small size of the module, short circuiting the output phases either to ground or the DC bus will destroy the bridge. The current limiting and control only works for current actually flowing through the bridge. The current sense resistor has to see the current in order for the electronics to control it. If possible, for startup use a lower voltage and lower current power supply to test out connections and the low current stability. With a limited current supply, even if the controller locks up, the dissipation will be limited. By observing the E/A OUT pin which is the error amp output, much can be found out about the health and stability of the system. An even waveform with some rounded triangle wave should be observed. As current goes up, the DC component of the waveform should move up or down. At full current (with a regular supply) the waveform should not exceed +4 volts positive peak, or -4 volts negative peak. Some audible noise will be heard which will be the commutation frequency. If the motor squeals, there is instability and power should be removed immediately unless power dissipation isn't excessive due to limited supply current. For compensation calculations, refer to the block diagram for all information to determine the amplifier gain for loop gain calculations. For the power up sequence, ± 15 volts should be powered at the same time or before the V+ voltage is applied.

# MSK4251 TEST CIRCUIT

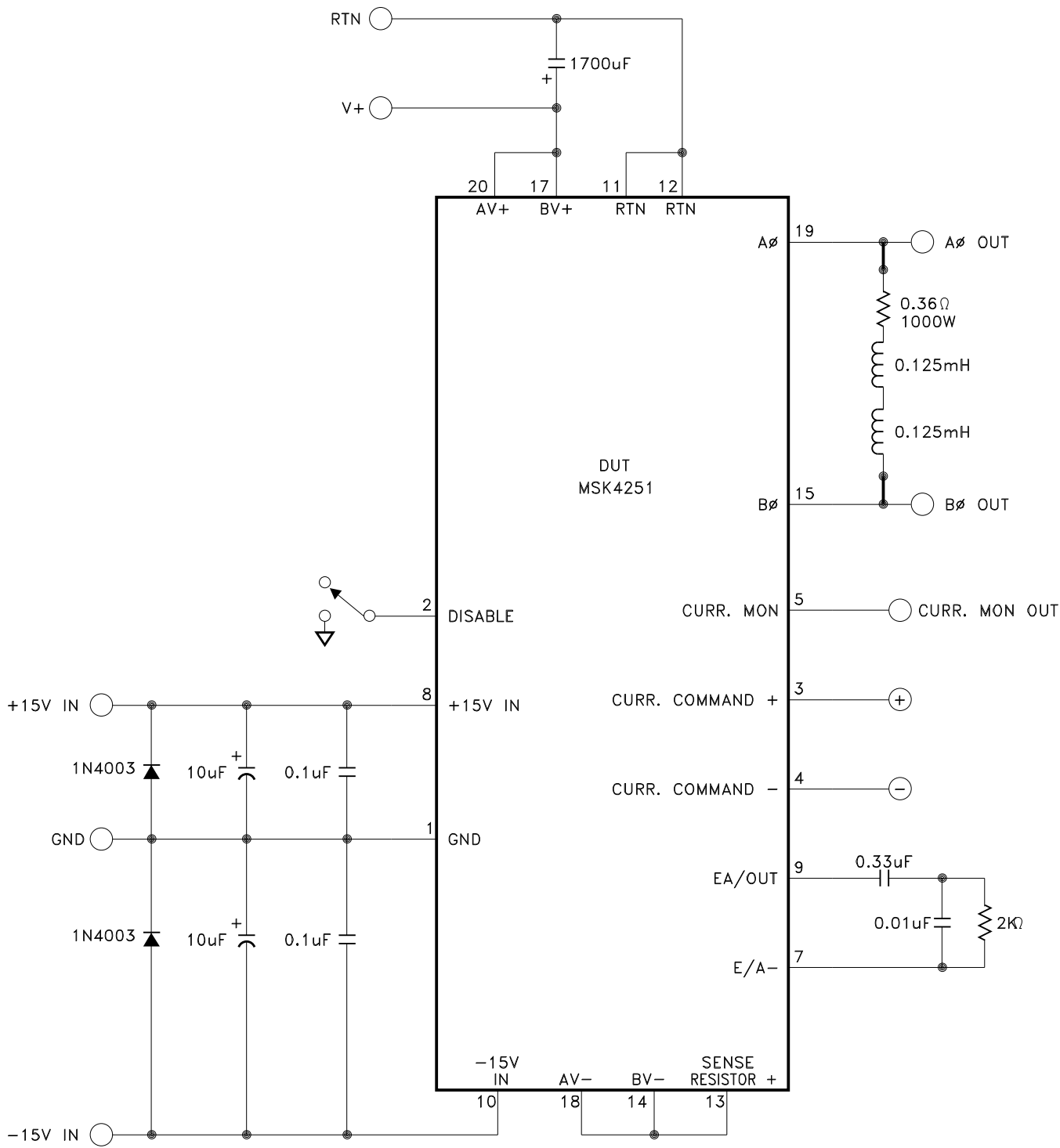

TYPICAL TEST SCHEMATIC

**MECHANICAL SPECIFICATIONS**

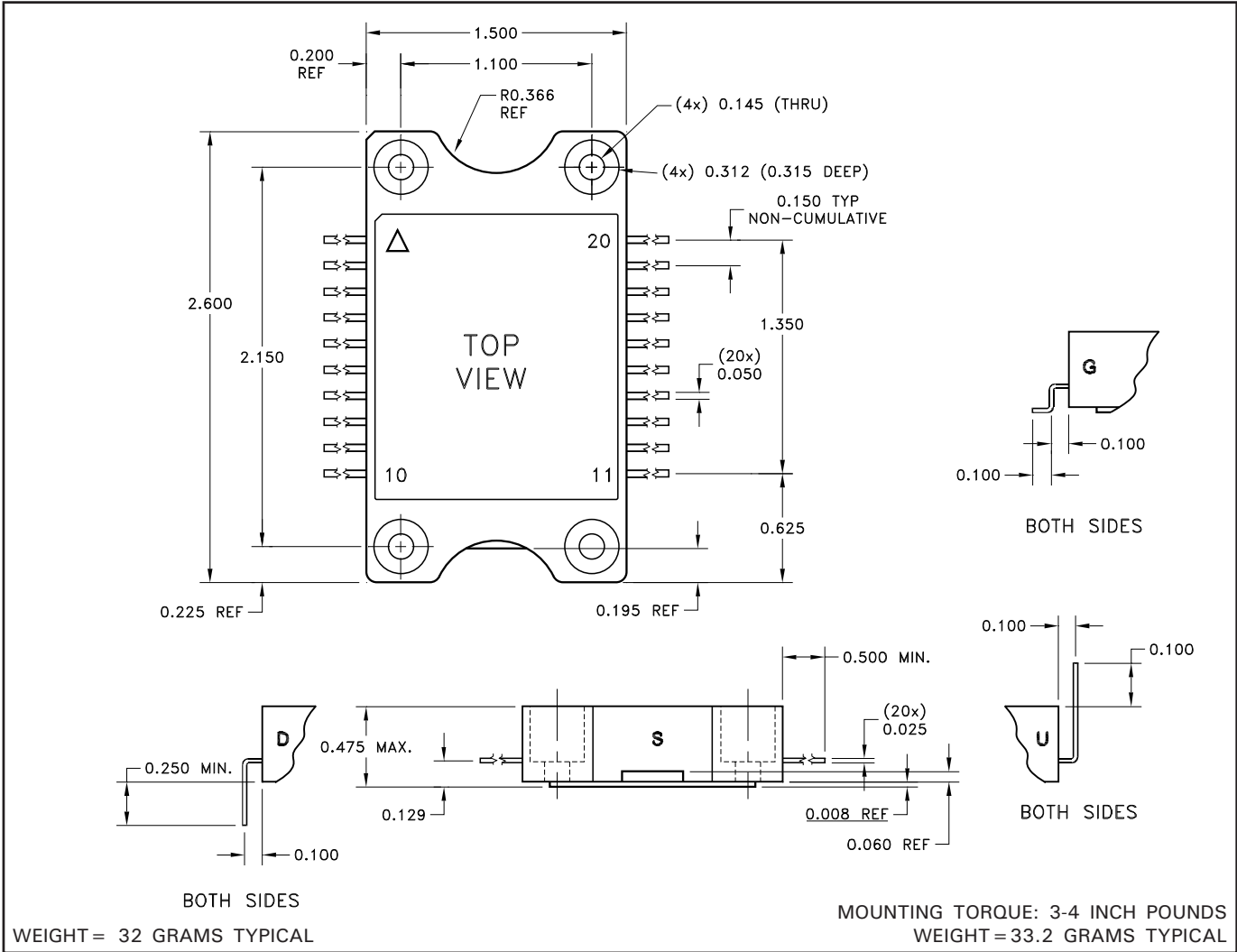

**CAUTION: THIS IS A NON-HERMETIC DEVICE. DO NOT EXPOSE PLASTIC HOUSING TO LIQUID**

**ORDERING INFORMATION**

Part Number	Screening Level	Lead Configuration
MSK4251S	Industrial	Straight
MSK4251D	Industrial	Down
MSK4251U	Industrial	Up
MSK4251G	Industrial	Gullwing

M.S. Kennedy Corp.  
 4707 Dey Road, Liverpool, New York 13088  
 Phone (315) 701-6751  
 FAX (315) 701-6752  
 www.mskennedy.com

The information contained herein is believed to be accurate at the time of printing. MSK reserves the right to make changes to its products or specifications without notice, however, and assumes no liability for the use of its products. Please visit our website for the most recent revision of this datasheet.