



**RAD HARD POSITIVE,
2.8A, LDO, SINGLE RESISTOR
ADJ VOLTAGE REGULATOR**

5984RH

FEATURES:

- Manufactured using  Space Qualified RH3083 Die
- MIL-PRF-38534 Class K Processing & Screening
- Total Dose Hardened to 100 Krads(Si) (Method 1019.7 Condition A)
- Total Dose Tested to 450 Krad(Si) (Method 1019.7 Condition A)
- Low Dropout to 310mV (VIN - VOUT, with Seperate Control Supply)
- Output Adjustable to Zero Volts
- Internal Short Circuit Current Limit
- Output Voltage is Adjustable with 1 External Resistor
- Output Current Capability to 2.8A
- Internal Thermal Overload Protection
- Outputs may be Paralleled for Higher Current
- Contact MSK for MIL-PRF-38534 Qualification Status

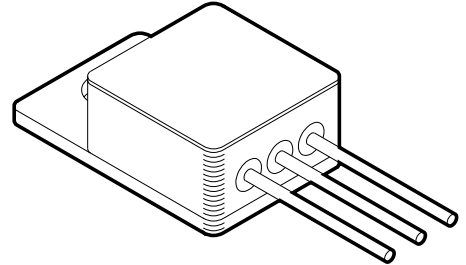

DESCRIPTION:

The MSK5984RH offers low dropout down to 310mV and an output voltage range down to zero volts while offering radiation tolerance for space applications. This, combined with the low θ_{JC} , allows increased output current while providing exceptional device efficiency. Output voltage is selected by the user through the use of 1 external resistor. Additionally, the regulator offers internal short circuit current and thermal limiting, which allows circuit protection and eliminates the need for external components and excessive derating. The MSK5984RH is hermetically sealed in a space efficient 3 pin package with straight, up and down pin configurations.

EQUIVALENT SCHEMATIC

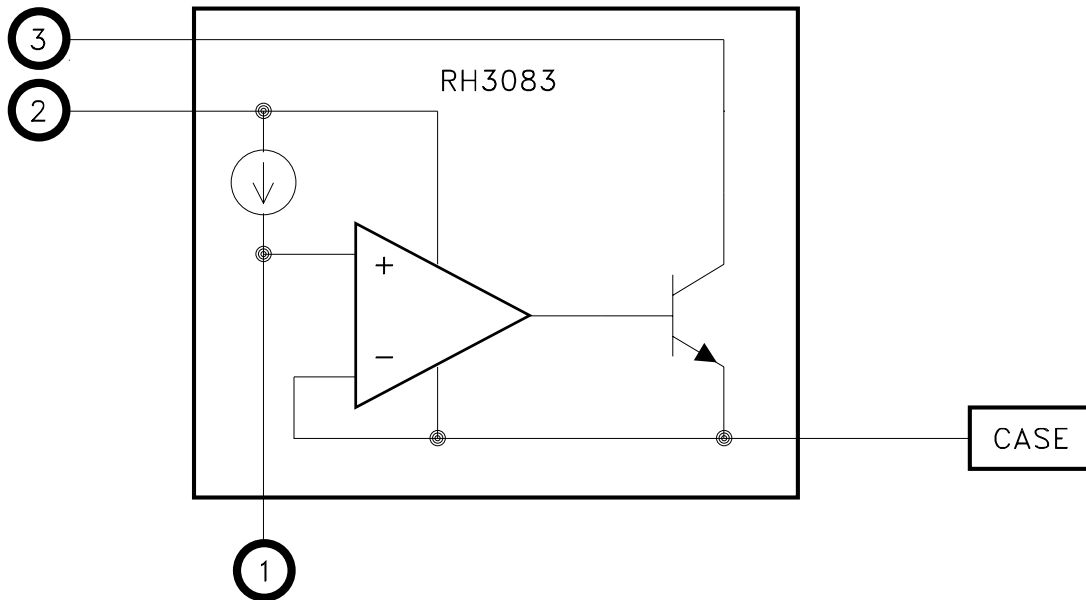

TYPICAL APPLICATIONS

- High Efficiency Linear Regulators
- Constant Voltage/Current Regulators
- Space System Power Supplies
- Switching Power Supply Post Regulators

PIN-OUT INFORMATION

- 1 SET
 - 2 CONTROL
 - 3 VIN
- CASE=VOUT

 and the Linear Technology logo are registered trademarks and RH3083 is a copyright of Linear Technology Corporation

ABSOLUTE MAXIMUM RATINGS ⁽¹⁰⁾

VIN	Input Voltage... ⁽⁷⁾	+18V, -0.3V	Pd	Power Dissipation.....	Internally Limited
	No Overload or Short... ⁽⁷⁾	+23V,-0.3V	TJ	Junction Temperature.....	+150°C
VCONTROL	Control Pin Voltage... ⁽⁷⁾	±28V	TST	Storage Temperature Range.....	-65°C to +150°C
IOUT	Output Current... ⁽⁸⁾	3.0A	TLD	Lead Temperature Range (10 Seconds).....	300°C
ISET	Set Pin Current	±25mA	Tc	Case Operating Temperature	
VSET	Set Pin Voltage... ⁽⁷⁾	±10V		MSK5984RH.....	-40°C to +85°C
				MSK5984K/H RH.....	-55°C to +125°C
				ESD Rating.....	CLASS 2

ELECTRICAL SPECIFICATIONS

Parameter	Test Conditions ⁽¹⁾ ⁽¹¹⁾	Group A Subgroup	MSK 5984K/H RH			MSK 5984RH			Units	
			Min.	Typ.	Max.	Min.	Typ.	Max.		
Set Pin Current (ISET)	VCONTROL = VIN = 3.0V VOUT = 1.0V 5mA ≤ ILOAD ≤ 2.8A	1	49.5	50	50.5	49.5	50	50.5	uA	
		2, 3	49	-	51.5	-	-	-	uA	
		Post Radiation	1	49	-	51	49	-	51	uA
Output Offset Voltage (VOS)	VCONTROL = VIN = 3.0V VOUT = 1.0V ILOAD = 5mA	1	-4.5	0	4.5	-4.5	0	4.5	mV	
		2, 3	-6	-	6	-	-	-	mV	
Load Regulation	VCONTROL = VIN = 3.0V VOUT = 0V 5mA ≤ ILOAD ≤ 2.8A (ΔVOS) (ΔISET)	1, 2, 3	-4	-	4	-4	-	4	mV	
		1, 2, 3	-300	-10	+300	-300	-10	+300	nA	
Line Regulation	ΔVIN = 2V TO 24V ΔVCONTROL = 3V TO 24V (ΔVOS) VOUT = 0V ILOAD = 5mA (ΔISET)	1, 2, 3	-0.05	-	0.05	-0.05	-	0.05	mV/V	
		1, 2, 3	-10	0.1	+10	-10	0.1	+10	nA/V	
VIN Dropout Voltage	VOUT = 1.0V ILOAD = 2.8A VCONTROL = 3.0V	1	-	310	700	-	310	700	mV	
		2, 3	-	-	800	-	-	-	mV	
VIN+ Control Pin Dropout Voltage ⁽²⁾	VOUT = 1.0V, ILOAD = 2.8A	1% ΔVOUT	1	-	1.66	-	-	1.66	-	V
		10% ΔVOUT	1	-	1.25	-	-	1.25	-	V
Control Pin Dropout Voltage	VOUT = 1.0V ILOAD = 2.8A VIN = 3.0V	1	-	1.25	1.55	-	1.25	1.55	V	
		2, 3	-	-	1.65	-	-	-	V	
Control Pin Current	VIN = 2.0V VOUT = 1.0V ILOAD = 100mA VCONTROL = 3.0V ILOAD = 100mA	ILOAD = 100mA	1, 2, 3	-	5.5	11	-	5.5	11	mA
		ILOAD = 2.8A	1, 2, 3	-	50	100	-	50	100	mA
Current Limit ⁽⁹⁾	VCONTROL = VIN = 5.0V VOUT = 1.0V	1	2.8	3.6	-	2.8	3.6	-	A	
		2, 3	2.8	-	-	-	-	-	A	
Minimum Load Current ⁽⁶⁾	VCONTROL = VIN = 23V	-	-	-	1	-	-	1	mA	
Ripple Rejection ⁽²⁾	F = 120Hz ΔVIN = 0.5Vpp IOUT = 0.1A CSET = 0.1uF	-	-	85	-	-	85	-	dB	
Output Noise ⁽²⁾	VIN = VCONTROL = 3V, IOUT = 500mA 10Hz to 100KHz CSET = 0.1uF	-	-	40	-	-	40	-	uVRMS	
Thermal Resistance ⁽²⁾	Junction to Case @ 125°C	-	-	2.3	2.9	-	2.3	2.9	°C/W	

NOTES:

- ① Output is decoupled to ground using a 220μF tantalum low ESR capacitor in parallel with 3 pieces of 1.0μF and one 0.1μF ceramic capacitor unless otherwise specified. (See Figure 1)
- ② Guaranteed by design but not tested. Typical parameters are representative of actual device performance but are for reference only.
- ③ Logic input levels are verified during logic output voltage test.
- ④ Industrial grade devices shall be tested to subgroup 1 unless otherwise requested.
- ⑤ Subgroup

1	TA = TC = +25°C
2	TA = TC = +125°C
3	TA = TC = -55°C
- ⑥ Minimum load current verified while testing line regulation.
- ⑦ Voltage is measured with respect to VOUT.
- ⑧ Set pin is clamped to VOUT with diodes in series with 1KΩ resistors. Current will flow under transient conditions.
- ⑨ Reference current limit typical performance curve for output current capability versus voltage drop.
- ⑩ Continuous operation at or above absolute maximum ratings may adversely effect the device performance and/or life cycle.
- ⑪ Pre and Post irradiation limits at 25°C, up to 100 Krad(Si) TID, are identical unless otherwise specified.

APPLICATION NOTES

OUTPUT VOLTAGE

A single resistor (RSET) from the SET pin to ground creates the reference voltage for the internal Error Amplifier. The MSK5984RH SET pin supplies a constant current of 50µA that develops the reference voltage. The output voltage is simply $RSET \times 50\mu A$. Since the output is internally driven by a unity-gain amplifier, an alternative to using RSET is to connect a high quality reference source to the SET pin. With a minimum load requirement of 1mA on the Output, the Output Voltage can be adjusted to near 0V. To bring the output voltage to 0V, the load must be connected to a slightly negative voltage supply to sink the 1mA minimum load current from a 0V output.

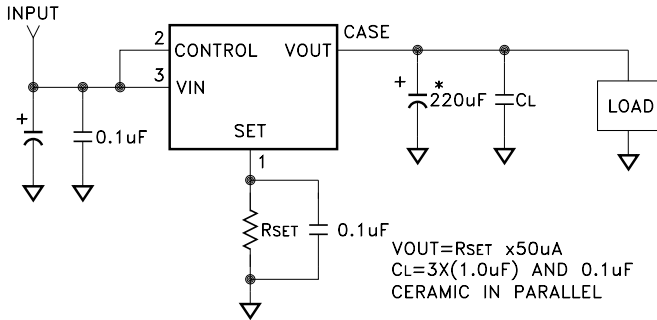

* TAZH227K010L
FIGURE 1

INPUT CAPACITANCE

Pins 3 is the connection to the collector of the power device of the MSK 5984RH. Output load current is supplied through these pins. Minimum input capacitance for these devices is 10µF. Low ESR, ceramic input capacitors are acceptable for applications without long input leads. For applications with long input leads, the self inductance of the wires can cause instability. Care must be taken to minimize the inductance of the input wires. This can be accomplished through the use of series resistance or higher ESR input capacitors. A minimum of 10µF of low ESR tantalum bulk capacitance in parallel with low value ceramic decoupling capacitance is recommended.

CONTROL PIN

The control pin is the bias supply for the control circuitry of the MSK5984RH. Minimum input capacitance on the control pin is 2.2µF. Approximately 1.7% of the output current flows into this pin. For proper regulation, the control pin voltage must be 1.6V greater than the output voltage. (See Control Dropout Voltage Specification).

OUTPUT CAPACITANCE

For stability purposes, the MSK5984RH requires a minimum output capacitor of 10µF with an ESR of 0.5Ω or less. Tantalum or ceramic capacitors are recommended. A larger capacitance value will improve transient response for increased load current changes. Consideration must also be given to temperature characteristics of the capacitors used.

LOW DROPOUT OPERATION

Using separate VIN and CONTROL power supplies allows for lower dropout and improved efficiency. Figure 2 shows the MSK5984RH output transistor collector is connected to the VIN pin. The regulator control circuitry is powered by the CONTROL input. The dropout of the regulator is determined by the saturation voltage of the output transistor, typical 300mV at 2.8A ILOAD. The CONTROL supply must supply the base drive current for the output transistor. The CONTROL current minus the 50µA SET current is supplied to the load. See the Typical Performance Characteristics curves for expected VIN dropout voltage. CONTROL pin dropout voltage and current requirements under various conditions. With separate supplies for VIN and CONTROL, power dissipation is reduced and efficiency improves.

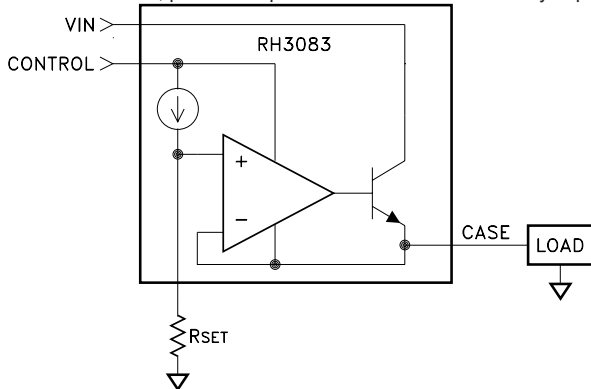

FIGURE 2

ADDITIONAL STABILITY

A capacitor placed in parallel with the SET pin resistor to ground, will improve the output transient response and filter noise in the system. To reduce output noise, typically 500-1000pF is required. Capacitors up to 1µF can be used, however consideration must be given to the effect the time constant created will have on the startup time.

LOAD REGULATION

The MSK5984RH specified load regulation is Kelvin Sensed, therefore the parasitic resistance of the system must be considered to design an acceptable load regulation. The overall load regulation includes the specified MSK5984RH load regulation plus the parasitic resistance multiplied by the load current as shown in Figure 3. RSO is the series resistance of all conductors between the MSK5984RH output and the load. It will directly increase output load regulation error by a voltage drop of $\Delta IO \times RSO$. RSS is the series resistance between the SET pin and the load. RSS will have little effect on load regulation if the SET pin trace is connected as close to the load as possible keeping the load return current on a separate trace as shown. RSR is the series resistance of all of the conductors between the load and the input power source return. RSR will not effect load regulation if the SET pin is connected with a Kelvin Sense type connection as shown in Figure 3, but it will increase the effective dropout voltage by a factor of $IO \times RSR$. Keeping RSO and RSR as low as possible will ensure minimal voltage drops and wasted power.

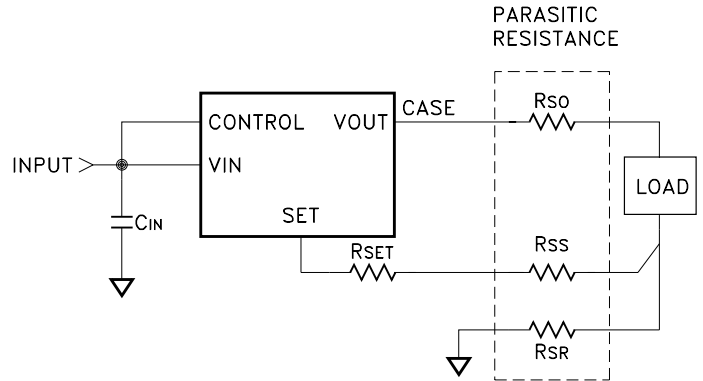

FIGURE 3

PARALLELING DEVICES

When currents greater than 2.8A are needed, the MSK5984RH's may be paralleled to multiply the current capacity. As shown in Figure 4, the VIN and SET pins must be tied together. The VOUT pins are connected to the load with consideration to the conductor resistance. The conductor resistance of each MSK5984RH VOUT connection to the load, must be equal to create equal load sharing. As little as 10mΩ ballast resistance typically ensures better than 80% equal sharing of load current at full load. Additional consideration must be given to the effect the additional VOUT conductor resistance has on load regulation; see paragraph titled "Load Regulation".

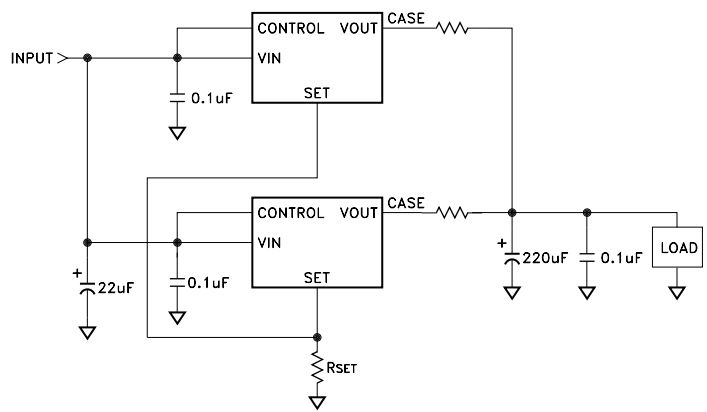

FIGURE 4

APPLICATION NOTES CONT'D

IMPROVING INITIAL ACCURACY AND REDUCING TEMPERATURE DRIFT

The initial output accuracy of the MSK5984RH due to SET pin current tolerance and set point resistor accuracy can be reduced to 0.2% using the MSK109RH radiation hardened precision reference. Minimal drift of the MSK109RH from temperature extremes and irradiation ensure very tight regulation. The circuit can be configured to use the 2.5V reference to directly set the output at 2.5V or with a slight variation it can provide any output within the operating range of the MSK5984RH down to 0V output. Select RS to maintain between 1mA and 10mA of current through the reference; see Figure 5 below. RS may be tied to VIN or another power source. The optional trim resistor can be used to further trim out initial output and system error. Reference the MSK109RH data sheet for application circuits that provide stable output voltages across the full operating range of the MSK5984RH including down to 0V output and the operating characteristics of the MSK109RH.

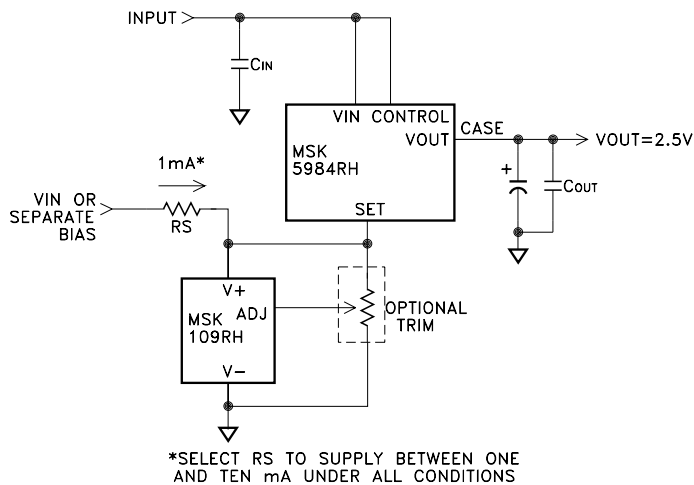

FIGURE 5

ADDING SHUTDOWN

The MSK5984RH can be easily shutdown by either reducing RSET to 0Ω or connecting a transistor from the SET pin to ground. By connecting two transistors, as shown in Figure 6, a low current voltage source is all that is required to take the SET pin to ground as well as pull the output voltage to ground. Q2 pulls the output voltage to ground when no load is present and only needs to sink 10mA.

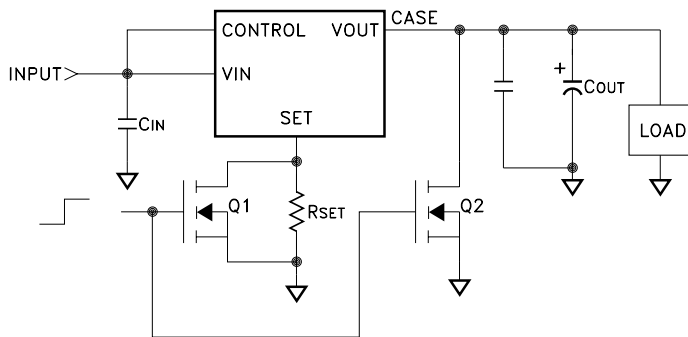

FIGURE 6

HEAT SINKING

To determine if a heat sink is required for your application and if so, what type, refer to the thermal model and governing equation below.

$$\text{Governing Equation: } T_J = P_D \times (R_{\theta_{JC}} + R_{\theta_{CS}} + R_{\theta_{SA}}) + T_A$$

WHERE

- T_J = Junction Temperature
- P_D = Total Power Dissipation
- $R_{\theta_{JC}}$ = Junction to Case Thermal Resistance
- $R_{\theta_{CS}}$ = Case to Heat Sink Thermal Resistance
- $R_{\theta_{SA}}$ = Heat Sink to Ambient Thermal Resistance
- T_C = Case Temperature
- T_A = Ambient Temperature
- T_S = Heat Sink Temperature

EXAMPLE:

This example demonstrates the thermal calculations for the regulator operating at 1.5A output current.

Conditions for MSK5984RH:

$$V_{\text{CONTROL}} = V_{\text{IN}} = +3.0\text{V}; I_{\text{OUT}} = +1.5\text{A } V_{\text{OUT}} = +1.0\text{V}$$

- 1.) Assume 45° heat spreading model.
- 2.) Find regulator power dissipation:

$$\begin{aligned} P_D &= (V_{\text{IN}} - V_{\text{OUT}})(I_{\text{OUT}}) \\ P_D &= (3-1)(1.50) \\ &= 3.0\text{W} \end{aligned}$$

- 3.) For conservative design, set $T_J = +125^\circ\text{C}$ Max.
- 4.) For this example, worst case $T_A = +90^\circ\text{C}$.
- 5.) $R_{\theta_{JC}} = 2.9^\circ\text{C/W}$ from the Electrical Specification Table.
- 6.) $R_{\theta_{CS}} = 0.15^\circ\text{C/W}$ for most thermal greases.
- 7.) Rearrange governing equation to solve for $R_{\theta_{SA}}$:

$$\begin{aligned} R_{\theta_{SA}} &= (T_J - T_A)/P_D - (R_{\theta_{JC}}) - (R_{\theta_{CS}}) \\ &= (125^\circ\text{C} - 90^\circ\text{C})/3.0\text{W} - 2.9^\circ\text{C/W} - 0.15^\circ\text{C/W} \\ &= 8.6^\circ\text{C/W} \end{aligned}$$

In this case the result is 8.6°C/W. Therefore, a heat sink with a thermal resistance of no more than 8.6°C/W must be used in this application to maintain regulator circuit junction temperature under 125°C.

TOTAL DOSE RADIATION TEST PERFORMANCE

Radiation performance curves for TID testing have been generated for all radiation testing performed by MSK. These curves show performance trends throughout the TID test process and can be located in the MSK5984RH radiation test report. The complete radiation test report will be available in the RAD HARD PRODUCTS section on the Anaren.com\MSK website.

ADDITIONAL APPLICATION INFORMATION

For additional applications information, please reference Linear Technology Corporation's® LT3083 and RH3083 data sheets.

TYPICAL PERFORMANCE CURVES

SET PIN CURRENT

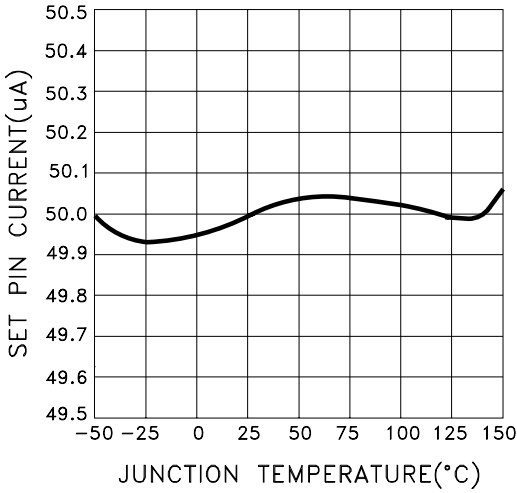

OFFSET VOLTAGE ($V_{OUT}-V_{SET}$)

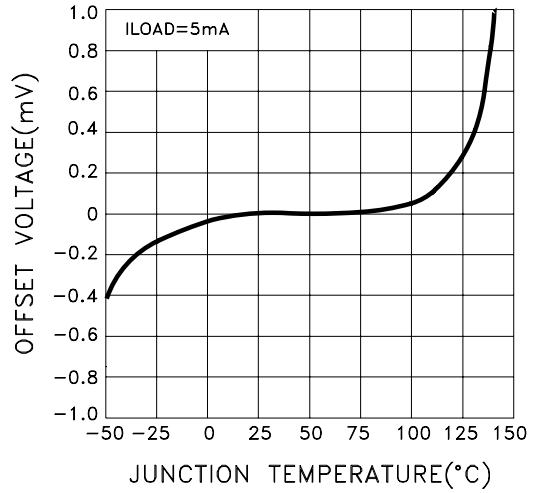

LOAD REGULATION

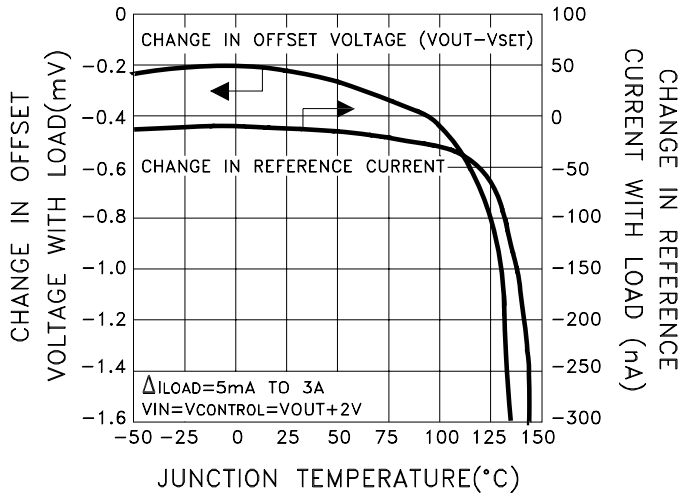

CURRENT LIMIT

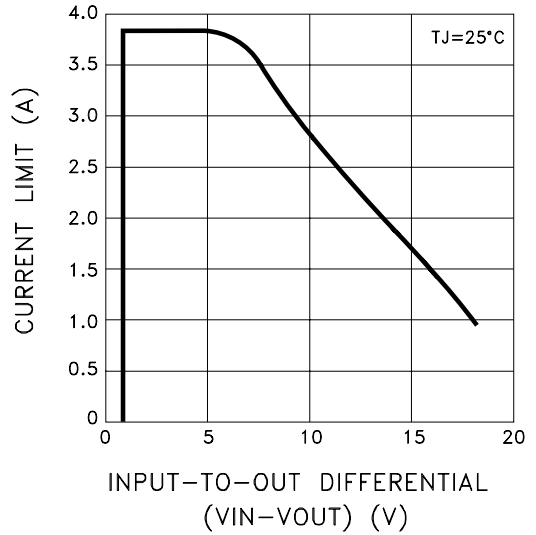

RIPPLE REJECTION (120Hz)

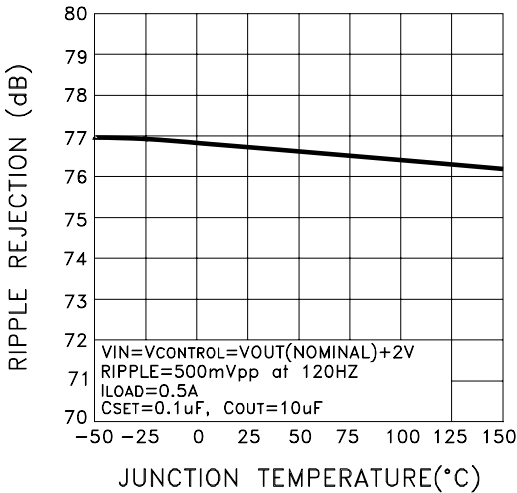

V_{IN} DROPOUT VOLTAGE

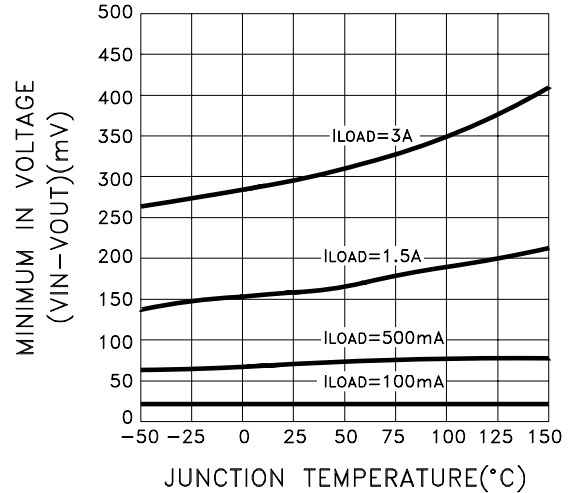

TYPICAL PERFORMANCE CURVES CONT'D

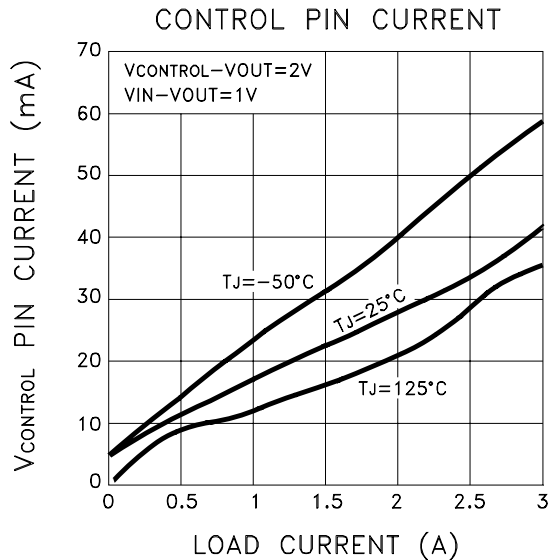
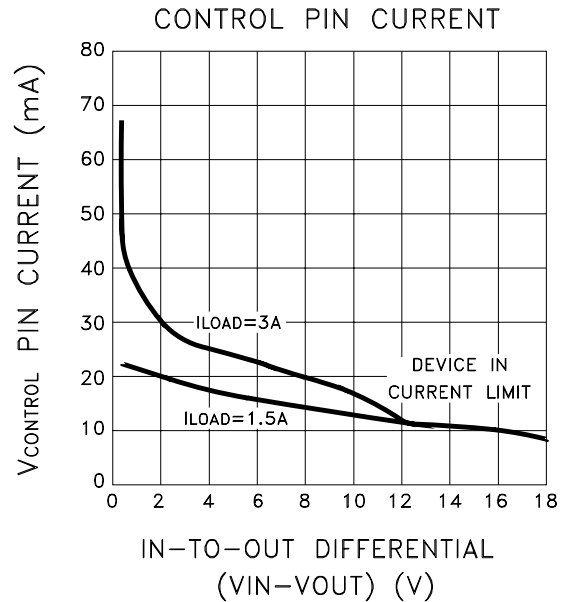
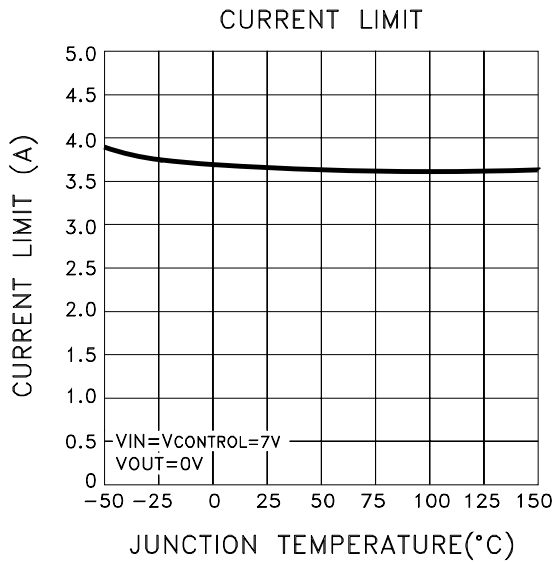
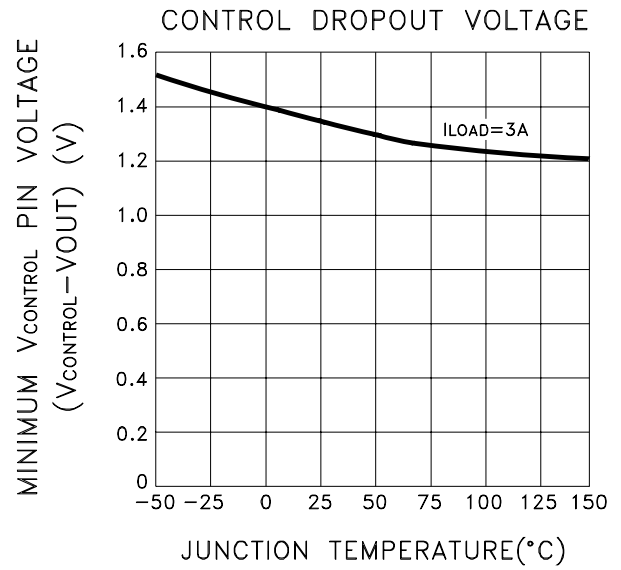
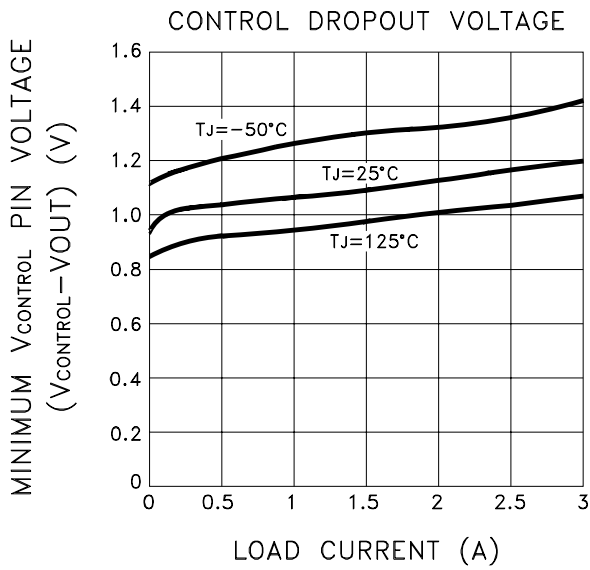

MECHANICAL SPECIFICATIONS

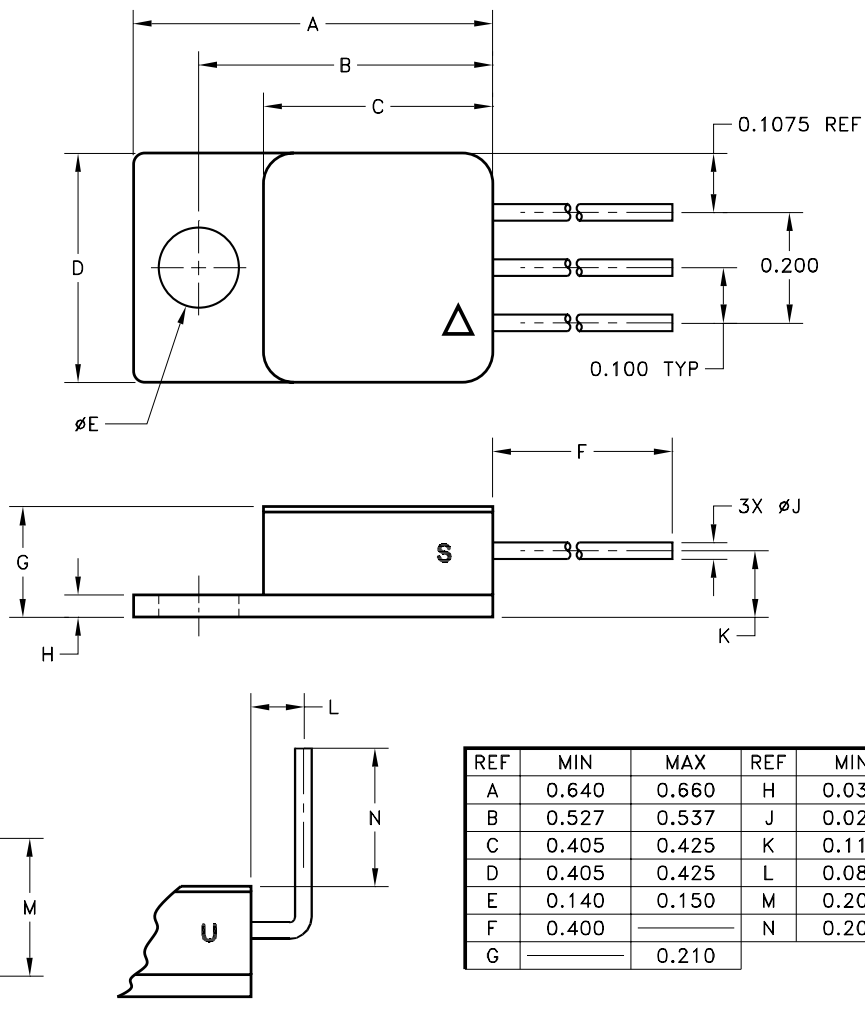

REF	MIN	MAX	REF	MIN	MAX
A	0.640	0.660	H	0.035	0.045
B	0.527	0.537	J	0.028	0.032
C	0.405	0.425	K	0.110	0.130
D	0.405	0.425	L	0.085	0.105
E	0.140	0.150	M	0.200	
F	0.400		N	0.200	
G		0.210			

ESD TRIANGLE INDICATES PIN 1
WEIGHT=3.2 GRAMS TYPICAL

ALL DIMENSIONS ARE SPECIFIED IN INCHES

ORDERING INFORMATION

MSK5984 K RH U

LEAD CONFIGURATIONS

S= STRAIGHT; U= BENT UP; D= BENT DOWN

RADIATION HARDENED

SCREENING

BLANK= INDUSTRIAL

H=MIL-PRF-38534 CLASS H; K=MIL-PRF-38534 CLASS K

GENERAL PART NUMBER

The above example is an adjustable Class K regulator with leads bent up.

REVISION HISTORY

REV	STATUS	DATE	DESCRIPTION
-	Preliminary	01/14	Initial Release
A	Preliminary	01/14	Add clarifications for block diagram, electrical specifications, max ratings and applications section.
B	Preliminary	03/14	Add clarifications.
C	Preliminary	08/14	Update electrical specifications.
D	Preliminary	04/16	Add class H under ordering information.
E	Preliminary	12/17	Add ESD Rating
F	Released	02/18	Update radiation status

ANAREN, MSK Products
www.anaren.com/msk

The information contained herein is believed to be accurate at the time of printing. Anaren, MSK products reserves the right to make changes to its products or specifications without notice, however and assumes no liability for the use of its products.

Please visit our website for the most recent revision of this datasheet.

Contact Anaren, MSK Products for MIL-PRF-38534 Class H, Class K qualification status.