

## MSK5978RH and MSK5980RH Evaluation Board User's Guide

By Bob Abel, Brent Erwin & Paul Musil, Anaren, Inc – MSK Products.; Revised 06/2017

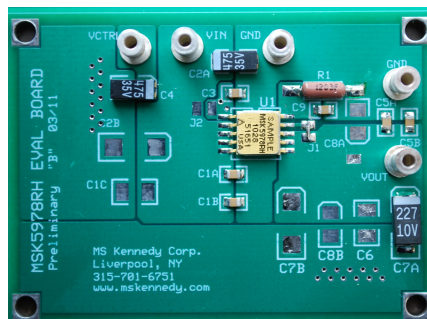

### Introduction

The MSK5978RH and MSK5980RH offer low dropout down to 250mV and an output voltage range down to zero volts while offering radiation tolerance for space applications. The low dropout voltage allows increased output current while providing exceptional device efficiency. Because of the increased efficiency, a small hermetic 10 pin ceramic flatpack can be used providing maximum performance while occupying minimal board space. The MSK5978RH and MSK5980RH are available in two lead options: straight or gull wing.

The evaluation board provides a platform from which to evaluate new designs with ample real estate to make changes and evaluate results. Evaluation early in the design phase reduces the likelihood of noise, instability, or other issues, becoming a problem at the application PCB level.

This application note is intended to be used in conjunction with the MSK5978RH, MSK5980RH and LT3080 data sheets. Reference those documents for additional application information and specifications.

### Setup

Use the standard turret terminals to connect to the power supply and test equipment. Connect your power supply across the  $V_{IN}$  and GND terminals. Leave the  $V_{OUT}$  SENSE jumper (J1) installed for proper operation. The CTL pin is used for dual supply operation. Connect the bias supply to the VCTRL and GND terminals when using dual supplies. For single supply operation, install J2. Minimum dropout voltage is possible

when the MSK5978RH and MSK5980RH are operated from dual supplies. Connect the output load between the VOUT and GND terminals. Use separate or Kelvin connections to connect input and output monitoring equipment. When measuring output voltage with an oscilloscope probe, the wire from the probe to the ground clip will act as an antenna, picking up excessive noise. For improved results, the test hook should be removed from the tip of the probe. The tip should be touched against the output turret, with the bare ground shield pressed against the ground turret. This reduces the noise induced from external sources. See the Typical Performance Characteristics curves in the data sheet for expected dropout voltage, CTL pin voltage, and current requirements under various conditions.

Note:

For dual supply operation, a 4.7 $\mu$ F capacitor, C4, from VCTL to ground is recommended to filter the VCTL power supply line. For single power supply operation, the VCTL pin is not independently used, and C4 is not required. There is enough bulk capacitance on the V<sub>IN</sub> pins.

### Output Voltage Programming

A single resistor (R<sub>SET</sub>) from the SET pin to ground creates the reference voltage for the internal Error Amplifier. The MSK 5978RH and MSK 5980RH SET pin supplies a constant current of 10 $\mu$ A that develops the reference voltage. The output voltage is simply R<sub>SET</sub> x 10 $\mu$ A. A low value ceramic capacitor placed across Rset will reduce output noise. Typically, 100pF is all that is required but capacitors up to 1 $\mu$ F can be used. The output voltage rise time will be controlled by the RC time constant RSET x CSET.

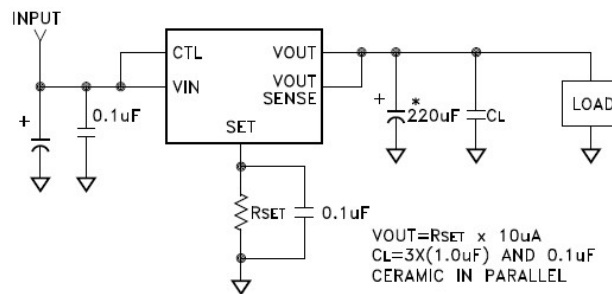

\* TAZH227K010L

Figure 1

### Efficiency

The efficiency of a typical linear regulator is approximated by V<sub>out</sub>/V<sub>in</sub>. The actual efficiency of an LDO regulator is slightly lower because of bias supplies and ground pin currents. Using separate V<sub>IN</sub> and V<sub>CTL</sub> power supplies allows for lower dropout and improved efficiency. The regulator control circuitry is powered by the V<sub>CTL</sub> input. The dropout of the regulator is determined by the saturation voltage of the output transistor, typically 250mV with a 0.7A I<sub>LOAD</sub>. The V<sub>CTL</sub> supply also supplies the base drive current for the output transistor. The V<sub>CTL</sub> current minus the 10 $\mu$ A SET current is supplied to the load. With separate supplies for V<sub>IN</sub> and V<sub>CTL</sub>, power dissipation is reduced and system efficiency improves.

$$\text{Efficiency} = 100\% \times P_{\text{OUT}} / (P_{\text{CTL}} + P_{\text{IN}})$$

Given:

$$P_{\text{OUT}} = V_{\text{OUT}} \times I_{\text{OUT}}$$

$$P_{\text{IN}} = V_{\text{IN}} \times I_{\text{IN}}$$

$$P_{\text{CTL}} = V_{\text{CTL}} \times I_{\text{CTL}}$$

$$\text{Where } I_{\text{IN}} = I_{\text{OUT}} - (I_{\text{CTL}} - I_{\text{SET}})$$

$I_{\text{CTL}}$  can be approximated from the curves

(Reference the control pin current curves in the MSK5978RH and MSK5980RH data sheet for more detail)

## Input/Output Capacitors

The MSK5978RH and MSK5980RH require a minimum output capacitor of 10 $\mu$ F with an ESR of 0.5 $\Omega$  or less. Tantalum or ceramic capacitors are recommended. A larger capacitance value will decrease the amplitude of transients, but will also decrease the bandwidth. The MSK evaluation board utilizes an AVX TAZ series 220 $\mu$ F tantalum output capacitor for increased gain and phase margin across a wide range of applications. The AVX TAZ series was chosen to provide a design starting point using high reliability MIL-PRF-55365/4 qualified capacitors. The input capacitor lowers the input bus impedance as seen by the regulator. The input capacitor requirements increase with increasing input bus impedance and decrease with decreasing impedance. Consideration must also be given to temperature characteristics of the capacitors used. A worst case circuit analysis is recommended for all applications to ensure end of life stability margins are sufficient.

## Loop Response

The plots below show the typical gain and phase response of the default configuration with a 100mA load.

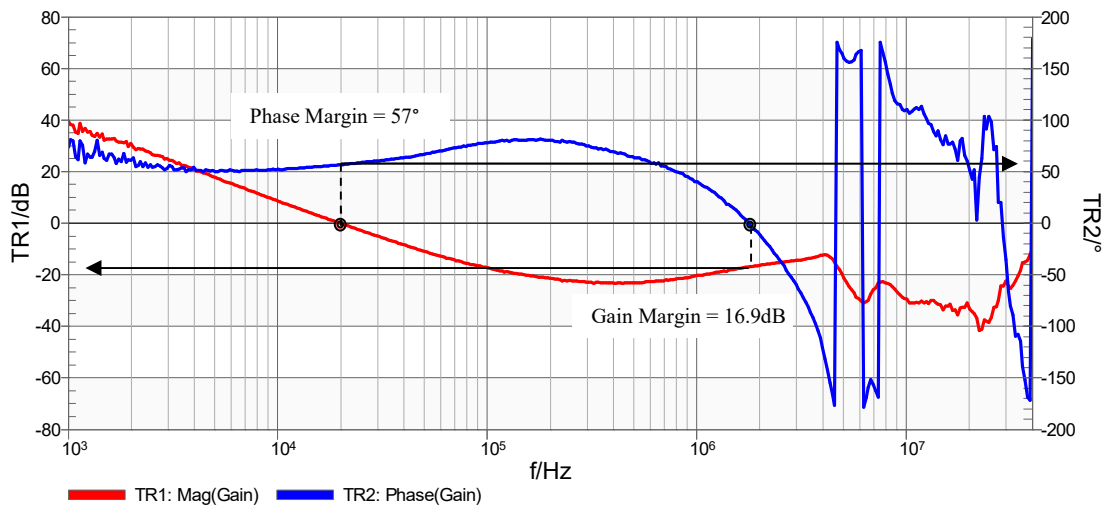

## Increased Accuracy

The accuracy of the output is dependent on several factors. The internal current source, the tolerance and temperature coefficient of the external resistor  $R_{SET}$ , and the output offset voltage. A high accuracy voltage reference such as the MSK109RH may be placed at the SET pin instead of  $R_{SET}$  to reduce the errors in output voltage caused by resistor tolerance and drift.

(Reference the application notes in the MSK109RH, MSK5978RH and MSK5980RH data sheets for more detail)

## Ripple Rejection

The chart below shows typical ripple rejection vs. frequency for the evaluation card application circuit at  $(V_{IN} - V_{OUT}) = 2V$  and  $I_{LOAD} = 500\text{ mA}$ . Ripple rejection measurements are sensitive to noise current in the ground plane. It may be necessary to move the bulk input capacitor to the input line to keep the bulk of the AC input current from influencing the measurement accuracy at the DUT.

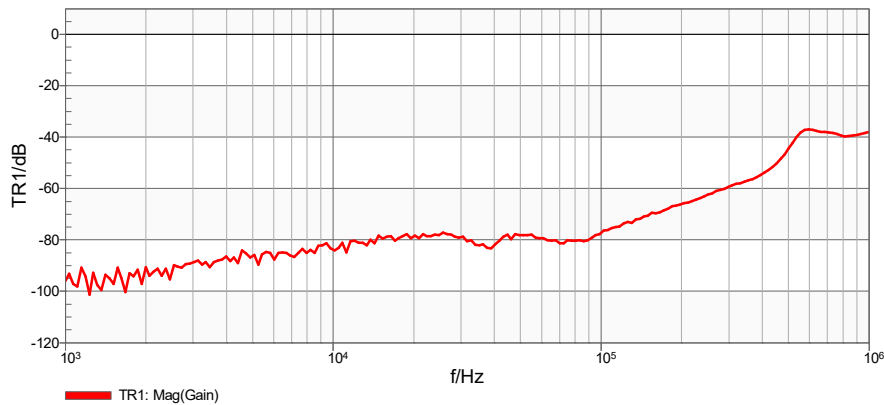

## Current Limitations

The output current limit decreases with increasing input voltage to prevent excessive power dissipation in the device.

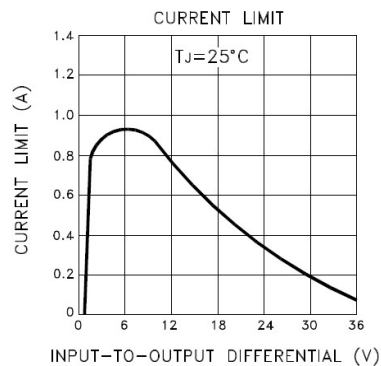

# MSK5978RH/MSK5980RH Evaluation Board Schematic

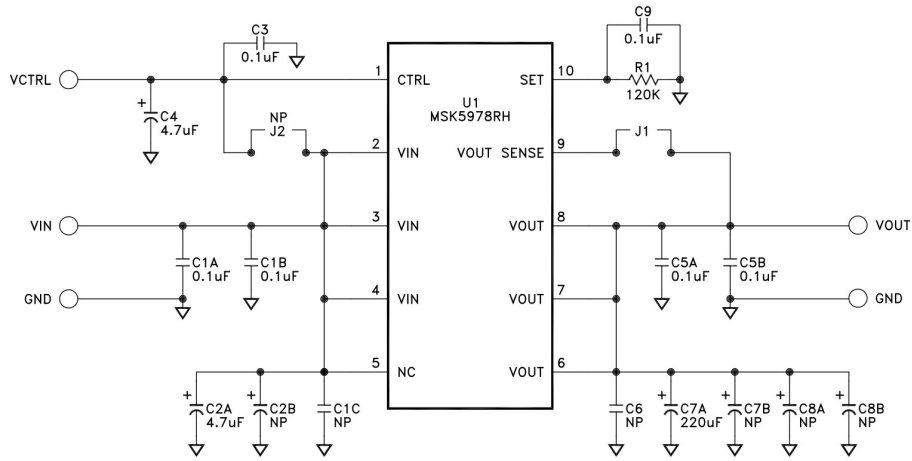

**NOTES:**

1. "NP" – NOT POPULATED COMPONENTS ARE NOT POPULATED SPACES PROVIDED FOR EVALUATION OF DIFFERENT ELECTRICAL CONFIGURATIONS.
2. SEE BOM FOR SPECIFIC COMPONENT INFORMATION.

## PCB Artwork

Top Side

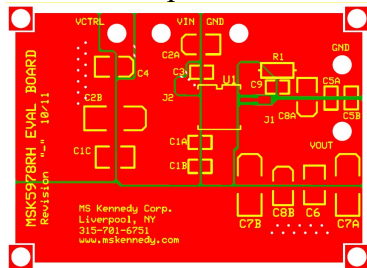

Bottom Side

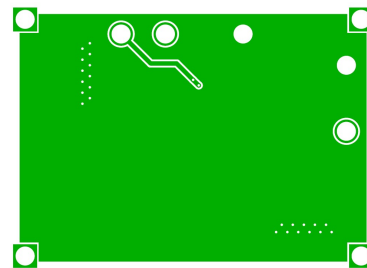

## Typical Performance

Parameter	Conditions	Units	Typical
Output Voltage	$R_{SET} \times 10\mu A$ , $R1 = 120K$ , 0.1%	V	1.2V(Factory Default)
Output Ripple Rejection	$F = 120 \text{ Hz}$ , $\Delta V_{IN} = 0.5V_{P-P}$	dB	75
Output Ripple Rejection	$F = 200kHz$ , $\Delta V_{IN} = 0.5V_{P-P}$	dB	35
Output Noise	$V_{in}=3V$ , $V_{ctrl}=3V$ , $R_{load}=2.5\Omega$ , $C9 = 0.1\mu F$	$\mu V_{RMS}$	31
Output Noise	$V_{in}=3V$ , $V_{ctrl}=3V$ , $R_{load}=2.5\Omega$ , $C9 = 100pF$	$\mu V_{RMS}$	59
Line Regulation	$3V \leq V_{IN} = V_{CTL} \leq 25V$ , $V_{OUT} = 1.2V$ , $I_{LOAD} = 1 \text{ mA}$	%	-0.014
Load Regulation	$V_{CTL} = V_{IN} = 3.0V$ , $V_{OUT} = 1.2V$ , $1 \text{ mA} \leq I_{LOAD} \leq$ $0.7A$	%	-0.13
Current Limit	$V_{CTL} = V_{IN} = 5.0V$ , $V_{OUT} =$ $1.2V$	A	.87
Minimum Load Current	$V_{CTL} = V_{IN} = 25V$	mA	1

## Bill Of Materials

---

Ref Des	Description	Manufacturer	Part Number
U1	Linear Regulator	MS Kennedy Corp.	MSK5978RH or MSK5980RH
C1A	8050 Ceramic cap 0.1uF	AVX	08051C104KAT
C1B	8050 Ceramic cap 0.1uF	AVX	08051C104KAT
C1C	N/A		
C2A	4.7 uF 35V Tantalum	AVX	TAZG475K035C (CWR09MC475K)
C2B	N/A	AVX	
C3	8050 Ceramic cap 0.1uF	AVX	08051C104KAT
C4	4.7 uF 35V Tantalum	AVX	TAZG475K035C (CWR09MC475K)
C5A	8050 Ceramic cap 0.1uF	AVX	08051C104KAT
C5B	8050 Ceramic cap 0.1uF	AVX	08051C104KAT
C6	N/A		
C7A	220 uF 10V Low ESR Tant.	AVX	TAZH227K010L (CWR29FC227K)
C7B	N/A		
C8A	N/A		
C8B	N/A		
C9	8050 Ceramic cap 0.1uF	AVX	08051C104KAT
R1	Resistor 120K, 1/8W		