



3A LOW NOISE, ADJUSTABLE LDO REGULATOR

5143

FEATURES:

- Fast Transient Response
- Low Dropout Voltage: 340mV @ 3A
- Low Noise: 40uVrms (10Hz to 100KHz)
- 1mA Quiescent Current
- Adjustable Output from 1.21V to 20V
- No Protection Diodes Required
- Stable with 10uF Output Capacitor
- Electrically Isolated Top Tab or Z Tab SIP
- Available in Three Lead Configurations
- Contact MSK for MIL-PRF-38534 Qualification Status

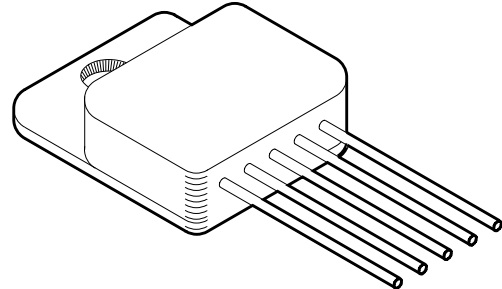

DESCRIPTION:

The MSK5143 adjustable output regulator offers a low 475mV dropout voltage while supplying up to 3A of output current. With fast transient response, these regulators have very low output noise. Excellent line and load regulation characteristics ensure accurate performance for multiple applications with a low operating quiescent current of 1mA that drops to < 1µA at shutdown. These regulators offer internal short circuit current limit, thermal limiting and reverse current protection which eliminates the need for external components and excessive derating. The MSK5143 is available in a hermetically sealed space efficient 5 pin power SIP available in two styles with three lead bend options.

EQUIVALENT SCHEMATIC

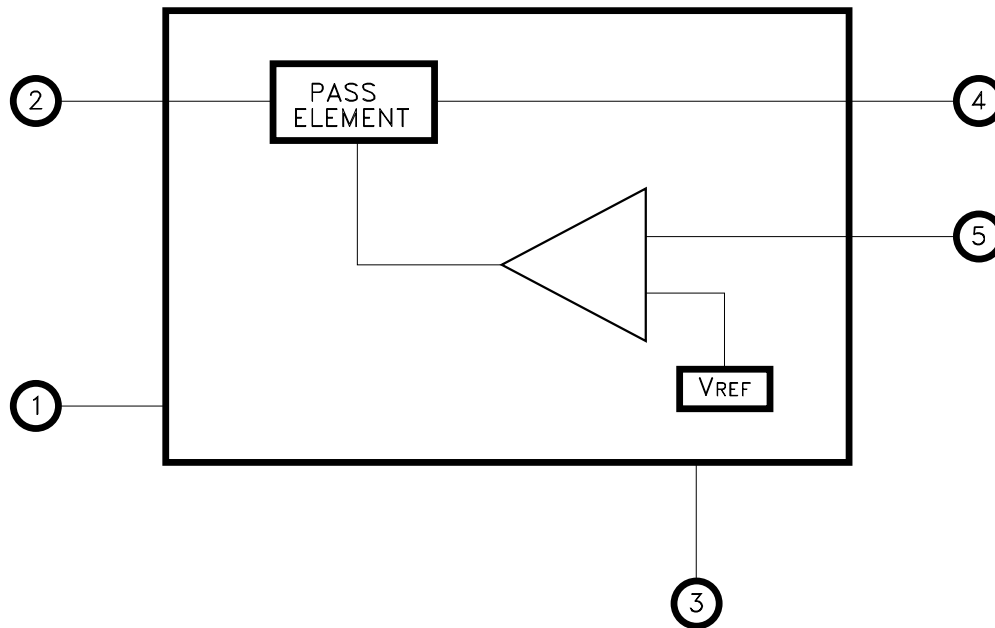

TYPICAL APPLICATIONS

- Post Regulator For Switching Power Supplies
- Battery Powered Equipment
- Microprocessor Power Supplies
- Pre-amplifier Power Supplies

PIN-OUT INFORMATION

- 1 $\overline{\text{SHDN}}$
 - 2 VIN
 - 3 GND
 - 4 VOUT
 - 5 ADJ
- CASE=ISOLATED

ABSOLUTE MAXIMUM RATINGS ^⑩

IN	Supply Voltage.....	20V
I _{OUT}	Output Current.....	3A
V _{OUT}	Pin Voltage.....	20V
V _{IN}	Differential Input to Output Voltage.....	20V
ADJ	Pin Voltage.....	7V
SHDN	Pin Voltage.....	20V
ADJ	Pin Current.....	5mA

T _{ST}	Storage Temperature Range ^⑪	-65°C to +150°C
T _{LD}	Lead Temperature Range (10 Seconds).....	300°C
T _J	Junction Temperature.....	+150°C
T _C	Case Operating Temperature range MSK5143H.....	-55°C to +125°C
	MSK5143.....	-40°C to +85°C

ELECTRICAL SPECIFICATIONS

Parameter	Test Conditions ^①	Group A Subgroup	MSK5143H			MSK5143			Units
			Min.	Typ.	Max.	Min.	Typ.	Max.	
Minimum Input Voltage ^②	I _{LOAD} =0.5A	1	-	1.7	-	-	1.9	-	V
		1	-	2.3	2.8	-	2.3	2.8	V
		2,3	-	2.3	2.8	-	-	-	V
Adjust Pin Voltage ^⑥ ^⑦	2.8 < V _{IN} < 20V I _{OUT} =1mA V _{IN} =2.8V I _{OUT} =3A	1	1.174	1.210	1.246	1.174	1.210	1.246	V
		2,3	1.174	1.210	1.246	-	-	-	V
Line Regulation	V _{IN} =2.8V to 20V, V _{OUT} =1.21V I _{LOAD} =1mA	1	-1.0	-	1.0	-1.0	-	1.0	%
		2,3	-1.0	-	1.0	-	-	-	%
Load Regulation	V _{IN} =2.8V, V _{OUT} =1.5V Δ I _{LOAD} =1mA to 3A	1	-1.0	-	1.0	-1.0	-	1.0	%
		2,3	-1.5	-	1.5	-	-	-	%
Dropout Voltage ^⑧	I _{LOAD} =3A	1	-	0.475	0.55	-	-	0.55	V
		2,3	-	-	0.70	-	-	-	V
ADJ Pin Bias Current ^⑥		1	-	3	10	-	3	10	μA
Shutdown Threshold	V _{OUT} =Off to On V _{OUT} =On to Off	1	-	0.90	2.00	-	0.90	2.00	V
		1	0.25	0.55	-	0.25	0.55	-	V
SHDN Pin Current ^②	V _{SHDN} =0V V _{SHDN} =20V	1	-	0.01	1	-	0.01	1	μA
		1	-	3	30	-	3	30	μA
Quiescent Current in Shutdown	V _{SHDN} =0V	1	-	0.27	1.0	-	0.27	1.0	μA
GND Pin Current	V _{IN} =V _{OUT} +1V I _{LOAD} =0mA	1	-	0.77	2.50	-	0.77	2.50	mA
		2,3	-	0.77	2.50	-	-	-	mA
Output Voltage Noise ^②	C _{OUT} =10μF, I _{LOAD} =3A BW=10Hz to 100KHz	-	-	40	-	-	40	-	μV _{rms}
Ripple Rejection ^②	V _{IN} -V _{OUT} =1.5VDC, I _{LOAD} =0.75A V _{RIPPLE} (120Hz)=0.5V _{pp}	1	55	63	-	55	63	-	dB
Current Limit ^⑨	V _{IN} =V _{OUT} +1.2V	1	3.1	-	-	3.1	-	-	A
		2,3	3.1	-	-	-	-	-	A
Reverse Output Current ^②	V _{IN} <V _{OUT}	1	-	600	1200	-	600	1200	μA
Thermal Resistance ^②	Junction to Case @ 125°C	-	-	2.0	2.3	-	2.0	2.3	°C/W

- ① The output is decoupled to ground using a 100μF low ESR tantalum capacitor in parallel with a 1μF ceramic capacitor. See figure 1 for typical circuit. Guaranteed by design but not tested. Typical parameters are representative of actual device performance but are for reference only.
- ② Industrial grade devices shall be tested to subgroups 1 unless otherwise requested.
- ③ Military grade devices ("H" suffix) shall be 100% tested to subgroups 1,2 and 3.
- ④ Subgroup 1 TA=+25°C
- ⑤ Subgroup 2 TA=+125°C
Subgroup 3 TA=-55°C
Adjust pin connected to V_{OUT} pin.
- ⑥ Reference current limit typical performance curves for input to output differential limitations.
- ⑦ The minimum input voltage requirement must be maintained.
- ⑧ The output current limit function provides protection from transient overloads but it may exceed the maximum continuous rating.
- ⑨ Continuous operation in current limit may damage the device.
- ⑩ Continuous operation at or above absolute maximum ratings may adversely effect the device performance and/or life cycle.
- ⑪ Internal solder reflow temperature is 180°C, do not exceed.

OUTPUT ADJUST

The output voltage range of the MSK5143 is 1.21V to 20V. The output voltage is set by the ratio of two external resistors as shown in Figure 1. The device monitors the output to maintain the voltage at the ADJ pin. The ADJ pin is the input to the error amplifier. It has a bias current of 3μA which flows through R2 to the pin. The ADJ pin voltage is 1.21V referenced to ground. The value of R1 should be less than 4.17K to minimize errors in the output voltage caused by the ADJ pin bias current. Reference the typical performance curves for load regulation variation due to the change in the output voltage.

INPUT BYPASS CAPACITORS

Unless the regulator is located very close to the main input filter capacitor, a 1μF to 10μF low ESR tantalum capacitor should be added to the regulator's input to maximize transient response and minimize power supply transients. A 0.1μF ceramic capacitor should also be used for high frequency bypassing.

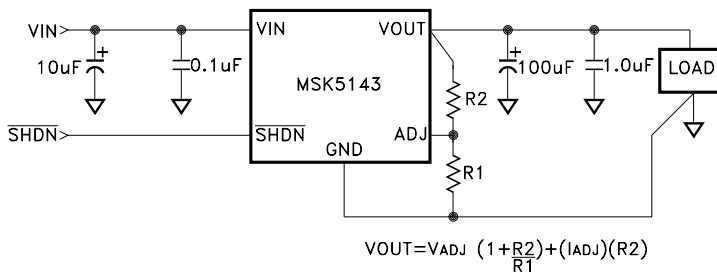

FIGURE 1

OUTPUT CAPACITOR SELECTION

For most applications a 10μF low ESR tantalum capacitor, as close to the regulators output as possible, is all that is required for the MSK5143 to be stable. When using a 10μF capacitor on the lower output voltage devices, a minimum ESR is required of the capacitor. This requirement decreases from 20mΩ for $V_{OUT} \leq 1.5V$ to 5mΩ for $V_{OUT} \geq 3.3V$. With an increase in capacitance, the minimum ESR requirement decreases. At 100μF, the minimum ESR requirement decreases to 5mΩ for all versions of the MSK5143. To reduce ringing and improve transient response, capacitors with slightly larger ESR in the range of 20mΩ to 50mΩ provides improved damping. Capacitors with higher ESR can be combined in parallel with low ESR ceramic capacitors for good high frequency response and settling time. The maximum ESR value must be less than 3Ω. Care must be taken when selecting a ceramic type. The X5R and X7R are the best choice for output stability when considering response due to applied voltage and temperature.

REVERSE VOLTAGE PROTECTION

The regulators are protected against reverse input and output voltages. Reverse input voltages up to 20V will be blocked from the input while current flow is limited to less than 1mA. The reverse voltage on the input is also prevented from appearing on the output and the load. When the input voltage is pulled down to ground and the output is held up by a second source, the current flow between them is limited to typically 600μA. See the electrical specifications table.

LOAD REGULATION

In voltage regulator applications where very large load currents are present, the load connection is very important. The path connecting the output of the regulator to the load must be extremely low impedance to avoid affecting the load regulation specifications. As shown in figure 2, any impedance (R_s) in this path will form a voltage divider with the load. For best results the ground pin should be connected directly to the load as shown in figure 2. The direct connection eliminates the effect the potential voltage drop in the power ground path can have on the internal ground sensing, thus improving load regulation. The MSK5143 ground pin trace must be designed to carry the ground pin current without significant voltage drops. See typical performance curves.

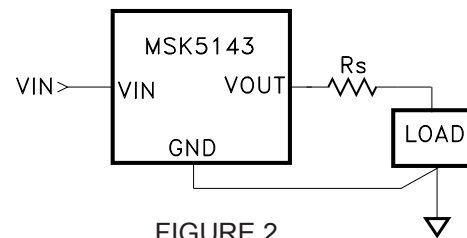

FIGURE 2

SHUTDOWN MODE

The \overline{SHDN} pin is used to put the regulator into its low power state. The output will be off when the \overline{SHDN} pin is pulled low. Quiescent current drops from 1mA to less the 1μA in shutdown mode. The \overline{SHDN} pin can be driven by 5V logic or open-collector logic with a pull-up resistor. The typical \overline{SHDN} pin current is 3μA. Connect the \overline{SHDN} pin to VIN if not used. If the \overline{SHDN} pin is not connected, the regulator will go into a low power shutdown state.

OVERLOAD PROTECTION

The MSK5143 regulator features both current limit and thermal overload protection. Within the safe operating region, the regulator will current limit above the 3A amp rating. As the input to output voltage increases, however, the current limit decreases to keep the output transistor within its power dissipation limitation. See the Current Limit Typical Curves for conditional performance detail. If the device heats enough to exceed its rated die junction temperature due to excessive ambient temperature, improper heat sinking etc., the regulator will shutdown until an appropriate junction temperature is maintained. To bring the regulator out of shutdown, the device input may need to be cycled to zero and power reapplied to eliminate the shutdown condition.

APPLICATION NOTES CONT'D

MINIMIZING POWER DISSIPATION:

To maximize the performance and reduce power dissipation of the MSK5143 device, VIN should be maintained as close to dropout or at VIN minimum when possible. See Input Supply Voltage requirements. A series resistor can be used to lower VIN close to the dropout specification, lowering the input to output voltage differential. In turn, this will decrease the power that the device is required to dissipate. Knowing peak current requirements and worst case voltages, a resistor can be selected that will drop a portion of the excess voltage and help to distribute the heating. The circuit below illustrates this method.

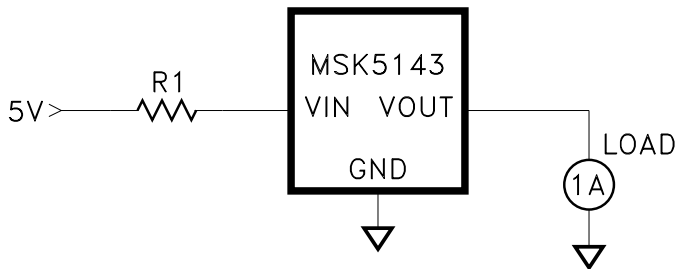

The maximum resistor value can be calculated from the following:

$$R1 \text{ max} = \frac{VIN \text{ min} - (VOUT \text{ max} + VDROP)}{IOUT \text{ peak} + GND \text{ Pin Current}}$$

Where:

VIN min=Minimum input voltage

VOUT max=Maximum output voltage across the full Temperature range

VDROP=Worst case dropout voltage (Typically 340mV)

IOUT peak=Maximum load current

GND Pin Current=Max. GND Pin Current at IOUT peak

HEAT SINK SELECTION

To select a heat sink for the MSK5143, the following formula for convective heat flow may be used.

Governing Equation:

$$T_J = P_D \times (R_{\theta JC} + R_{\theta CS} + R_{\theta SA}) + T_A$$

Where

TJ = Junction Temperature

PD = Total Power Dissipation

RθJC = Junction to Case Thermal Resistance

RθCS = Case to Heat Sink Thermal Resistance

RθSA = Heat Sink to Ambient Thermal Resistance

TA = Ambient Temperature

$$\text{Power Dissipation} = (VIN - VOUT) \times I_{OUT}$$

Next, the user must select a maximum junction temperature. The absolute maximum allowable junction temperature is 150°C. The equation may now be rearranged to solve for the required heat sink to ambient thermal resistance (RθSA).

Example:

An MSK5143 is connected for VIN=+5V and VOUT=+3.3V. IOUT is a continuous 2.5A DC level. The ambient temperature is +25°C. The maximum desired junction temperature is +125°C.

RθJC=2.3°C/W and RθCS=0.15°C/W for most thermal greases

$$\text{Power Dissipation} = (5V - 3.3V) \times (2.5A) = 4.25 \text{ Watts}$$

Solve for RθSA:

$$R_{\theta SA} = \left[\frac{125^\circ\text{C} - 25^\circ\text{C}}{4.25\text{W}} \right] - 2.3^\circ\text{C/W} - 0.15^\circ\text{C/W} = 21.1^\circ\text{C/W}$$

In this example, a heat sink with a thermal resistance of no more than 21.1°C/W must be used to maintain a maximum junction temperature of no more than 125°C.

TYPICAL PERFORMANCE CURVES

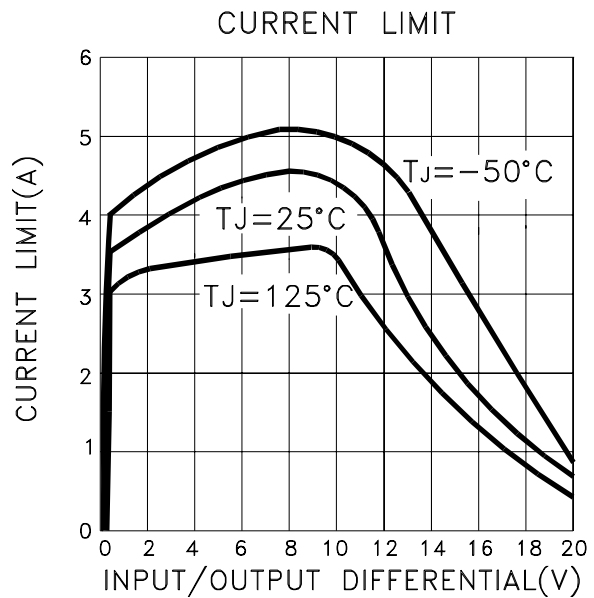
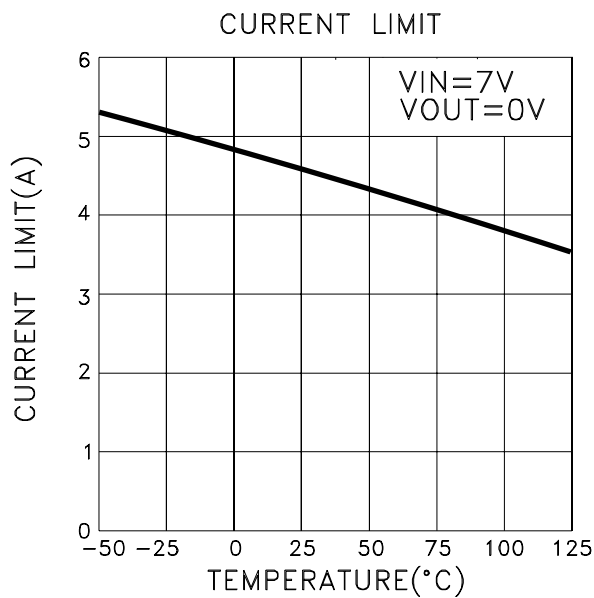
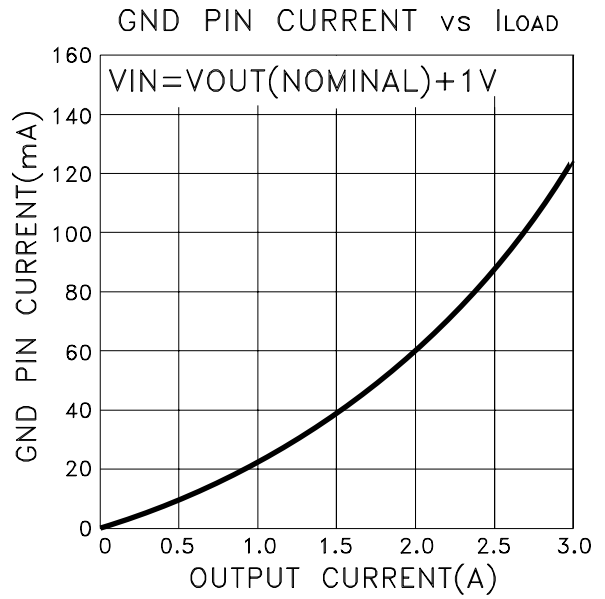
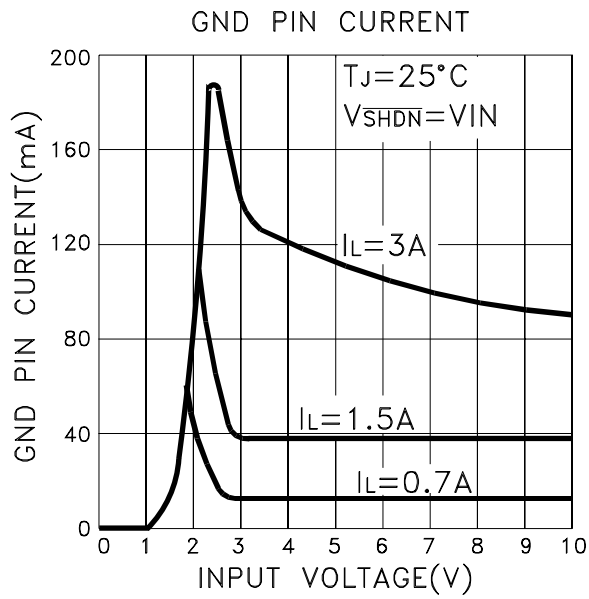
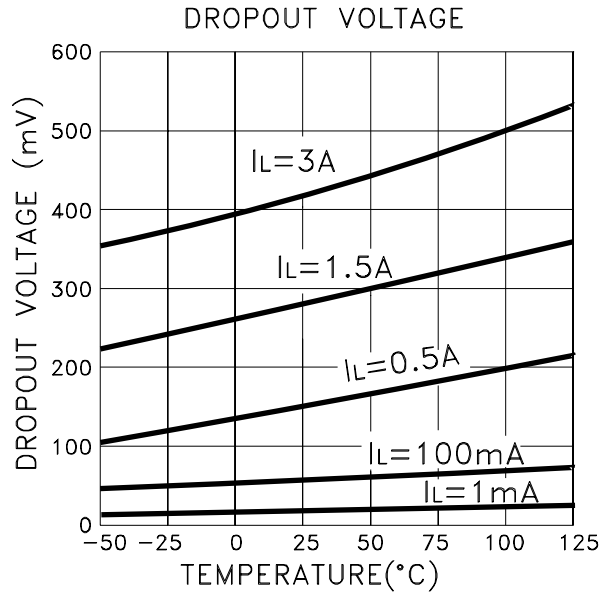
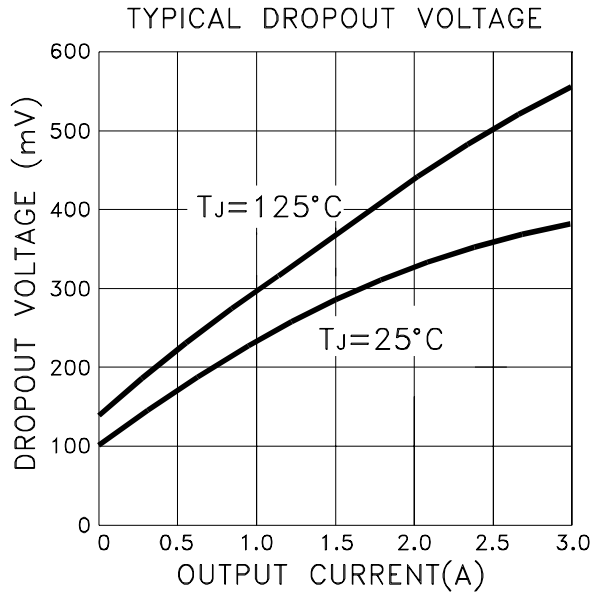

TYPICAL PERFORMANCE CURVES CONT'D

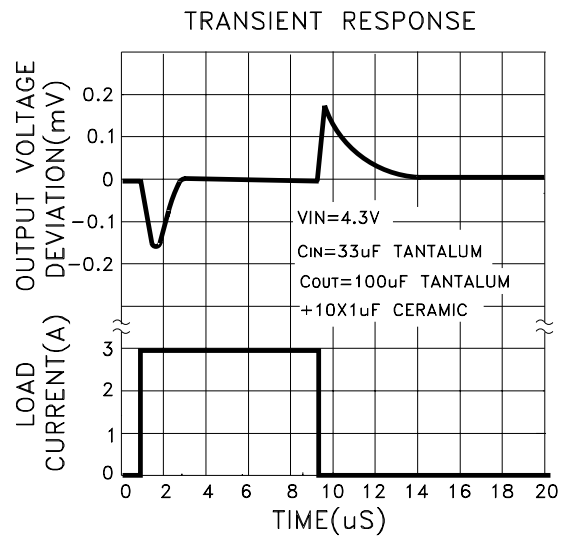
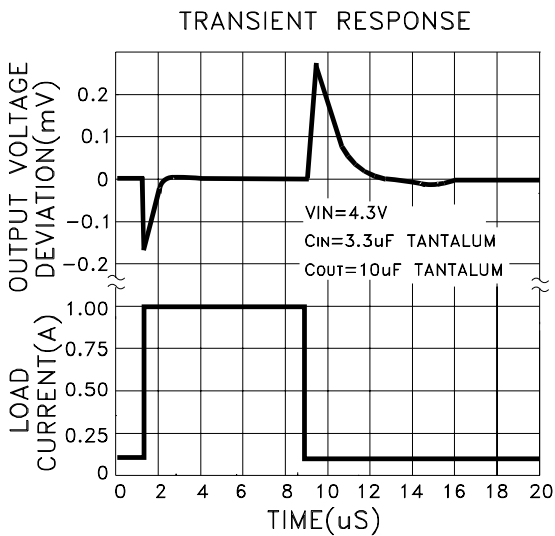
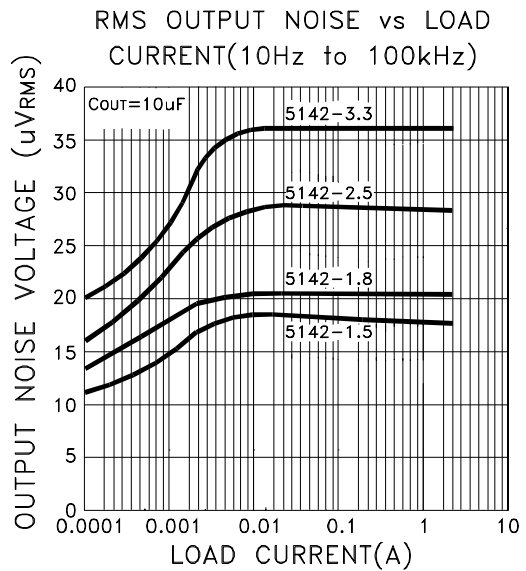
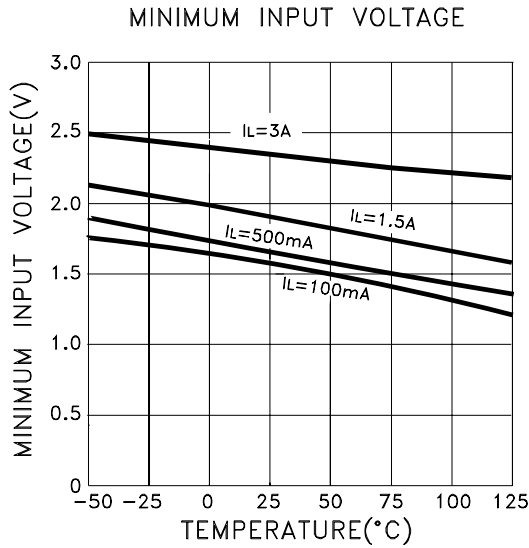
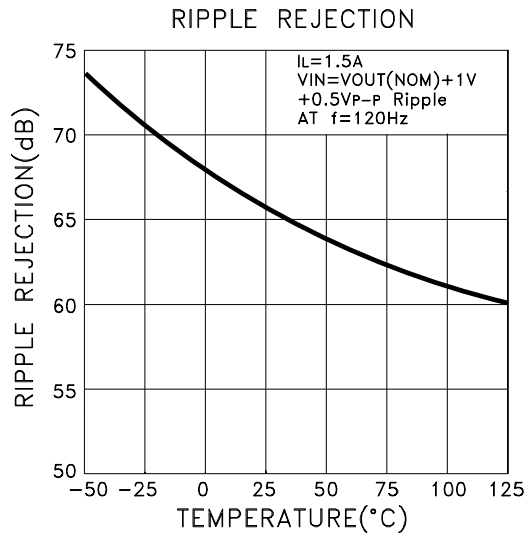
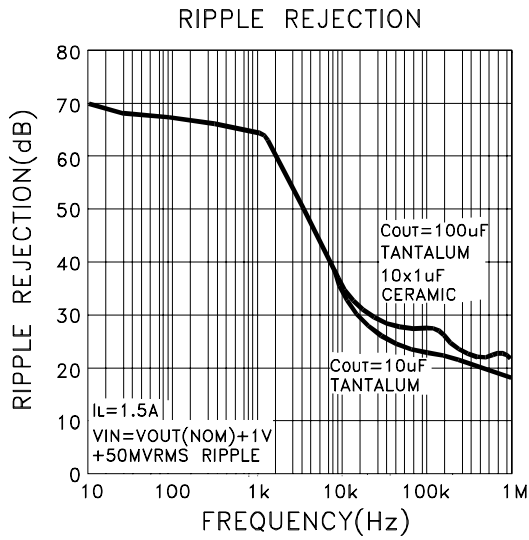

TYPICAL PERFORMANCE CURVES CONT'D

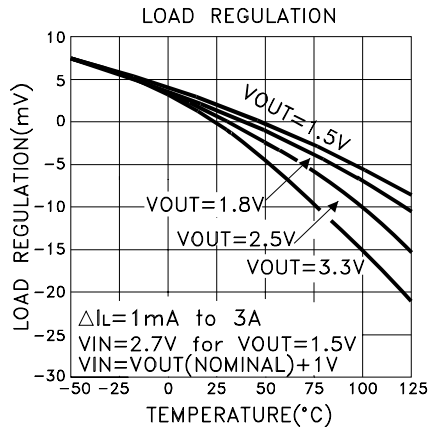
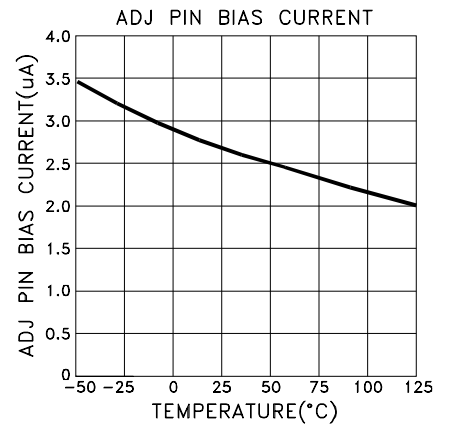
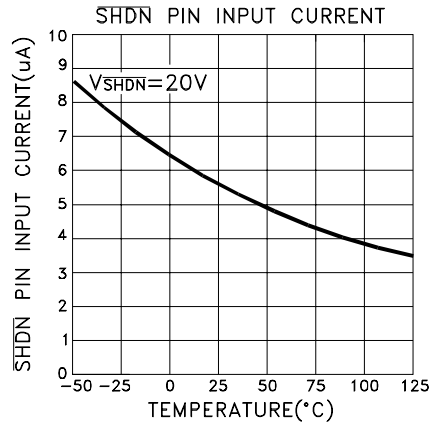
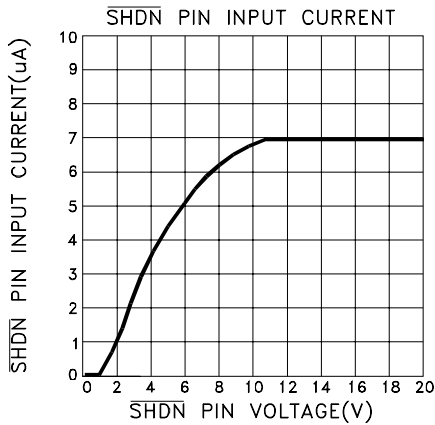
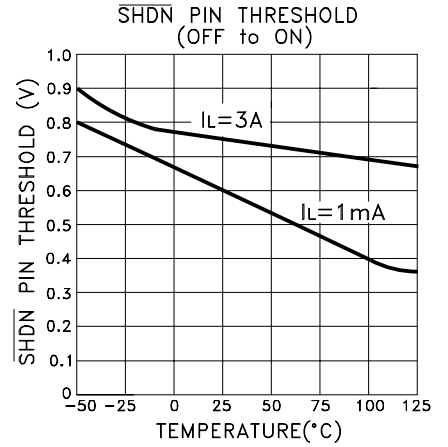
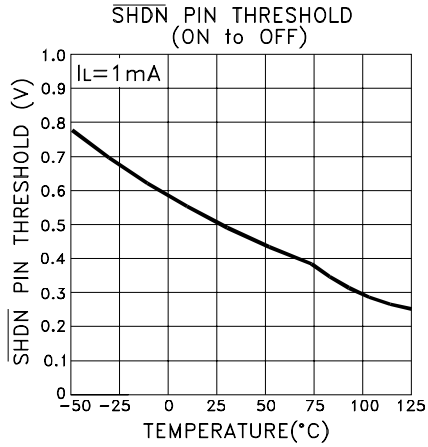
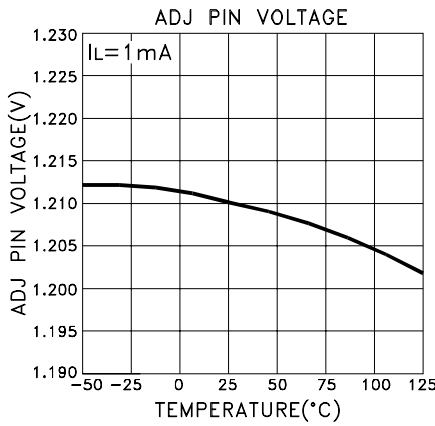

MECHANICAL SPECIFICATIONS

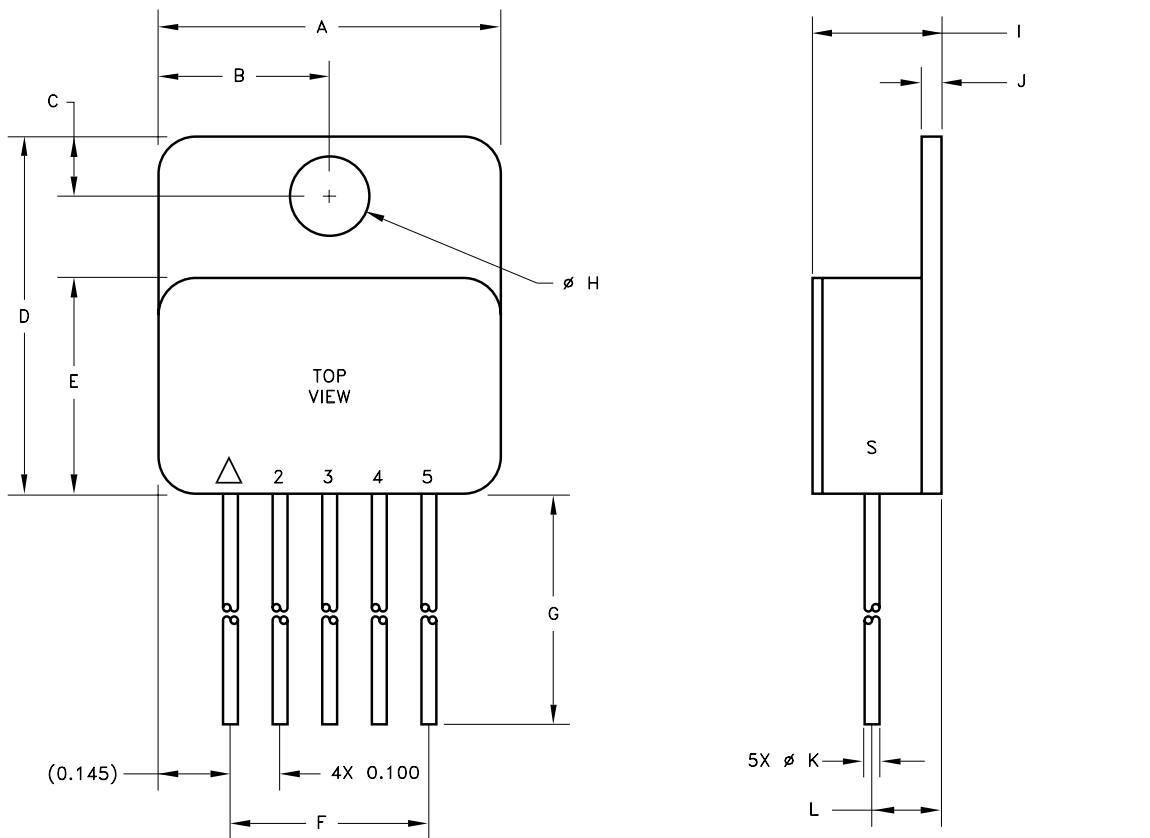

REF	MIN	MAX
A	0.680	0.700
B	0.340	0.350
C	0.113	0.123
D	0.815	0.825
E	0.525	0.545
F	0.395	0.405
G	0.500	
H	0.155	0.165
I		0.255
J	0.035	0.045
K	0.028	0.032
L	0.130	0.150
M	0.185	0.215
N	0.330	

ESD TRIANGLE INDICATES PIN 1
WEIGHT=7.7 GRAMS TYPICAL

ALL DIMENSIONS ARE SPECIFIED IN INCHES

ORDERING INFORMATION

MSK5143 H T U

- LEAD CONFIGURATIONS
S= STRAIGHT; U= BENT UP; D= BENT DOWN
- PACKAGE STYLE
T= TOP TAB
- SCREENING
BLANK= INDUSTRIAL; H=MIL-PRF - 38534 CLASS H
- GENERAL PART NUMBER

The above example is a Military regulator using the top tab package with leads bent up.

MECHANICAL SPECIFICATIONS CONT'D

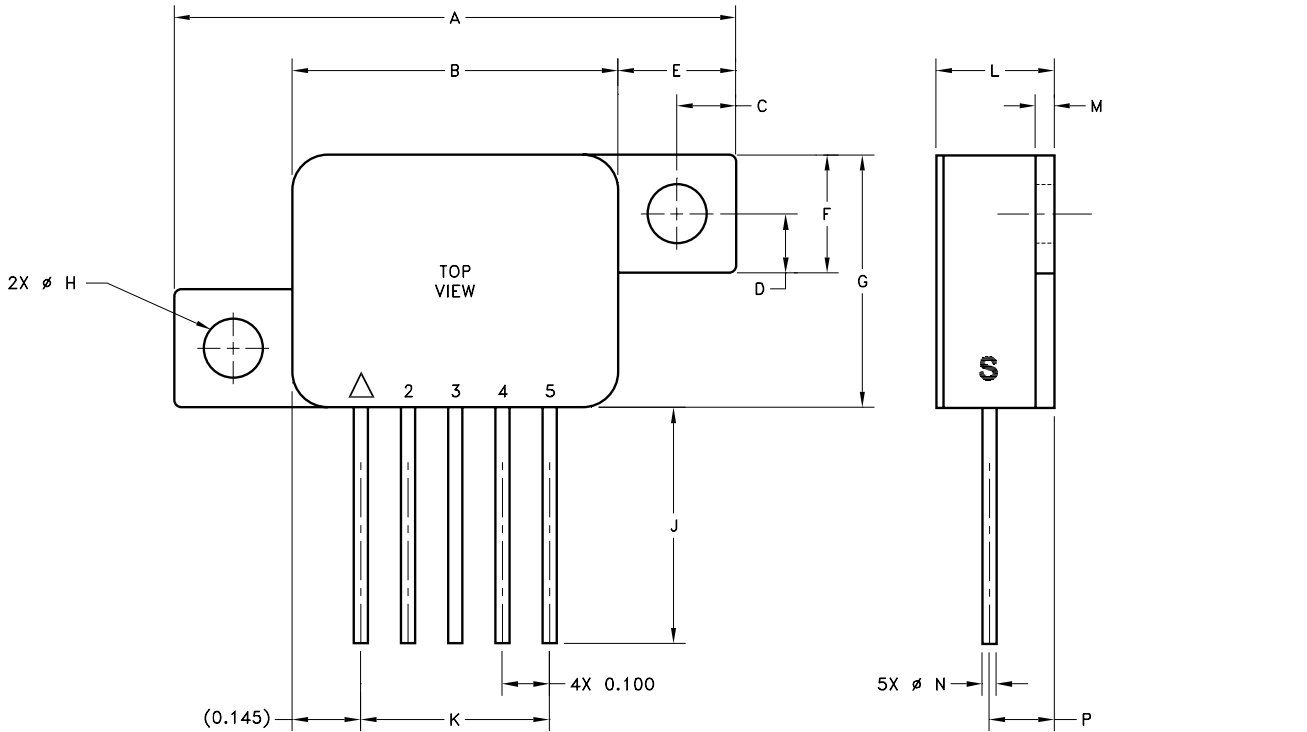

REF	MIN	MAX
A	1.185	1.195
B	0.680	0.700
C	0.120	0.130
D	0.120	0.130
E	0.245	0.255
F	0.245	0.255
G	0.525	0.545
H	0.120	0.130
J	0.500	
K	0.395	0.405
L		0.255
M	0.035	0.045
N	0.028	0.032
P	0.130	0.150
Q	0.185	0.215
R	0.330	

ESD TRIANGLE INDICATES PIN 1
WEIGHT=8.1 GRAMS TYPICAL

ALL DIMENSIONS ARE SPECIFIED IN INCHES

ORDERING INFORMATION

MSK5143 H Z U

- LEAD CONFIGURATIONS
S= STRAIGHT; U= BENT UP; D= BENT DOWN
- PACKAGE STYLE
Z= Z PACK
- SCREENING
BLANK= INDUSTRIAL; H=MIL-PRF - 38534 CLASS H
- GENERAL PART NUMBER

The above example is a Military regulator using the top tab package with leads bent up.

REVISION HISTORY

REV	STATUS	DATE	DESCRIPTION
E	Released	12/15	Add internal note and clarify mechanical specifications.

MSK
www.anaren.com/msk

The information contained herein is believed to be accurate at the time of printing. MSK reserves the right to make changes to its products or specifications without notice, however, and assumes no liability for the use of its products. Please visit our website for the most recent revision of this datasheet.
Contact MSK for MIL-PRF-38534 qualification status.