



**+2.5V RAD HARD  
PRECISION  
VOLTAGE REFERENCE**

**109RH**

**FEATURES:**

- Manufactured using  Space Qualified RH1009 Die
- MIL-PRF-38535 Class V Processing & Screening Available
- MIL-PRF-38534 Class H&K Processing & Screening Available
- Radiation Hardened to 100Krad(Si) (Method 1019.7 Condition A)
- Total Dose Tested to 450 Krads(Si) (Method 1019.7 Condition A)
- Wide Operating Current Range
- Maximum Initial Tolerance: 0.2%
- Excellent Temperature Stability
- Available in Straight or Gull Wing Lead Form
- Contact MSK for MIL-PRF-38534 Device Qualification Status

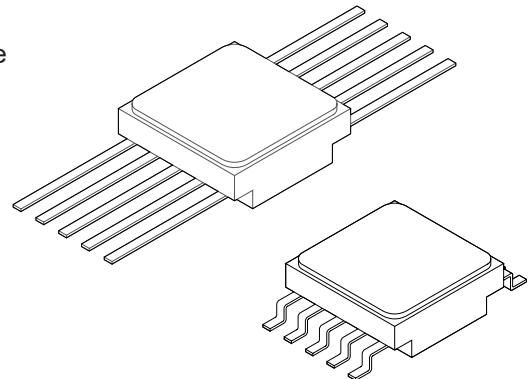

**DESCRIPTION:**

The MSK109RH is a 2.5V radiation hardened shunt regulator diode with an excellent initial voltage tolerance of  $\pm 5\text{mV}$  and very good stability over temperature. This voltage reference features a wide current range and a low dynamic impedance that is maintained over the full temperature range. The adjustment terminal allows the reference voltage to be adjusted to compensate for system errors. The MSK109RH is a hermetically sealed surface mount ceramic package with optional straight or gull wing lead form.

**EQUIVALENT SCHEMATIC**

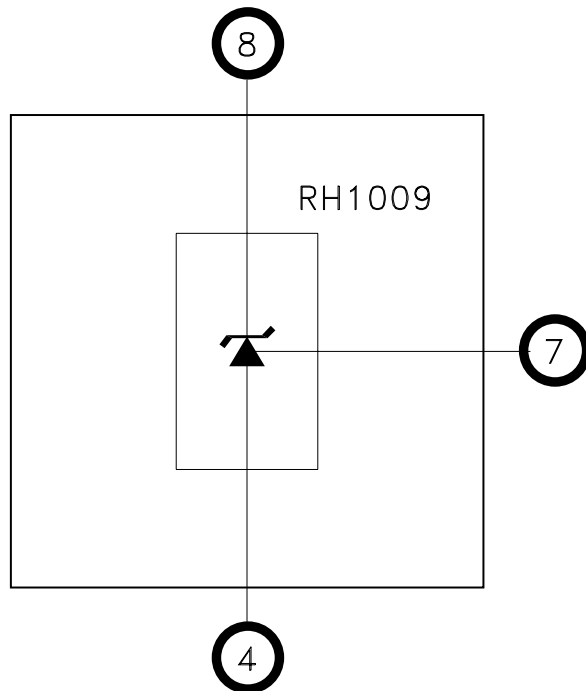

**TYPICAL APPLICATIONS**

- Precision Power Supply Reference
- Op Amp Circuitry
- Control Systems
- 8-Bit A/D and D/A Reference

**PIN-OUT INFORMATION**

1	NC	10	NC
2	NC	9	NC
3	NC	8	V+
4	V-	7	ADJ
5	NC	6	NC

LID = ISOLATED

 and the Linear Technology logo are registered trademarks and RH1009 is a copyright of Linear Technology Corporation

## ABSOLUTE MAXIMUM RATINGS

⑥

Reverse Current..... 20mA  
 Forward Current..... 10mA  
 Tc Case Operating Temperature Range  
 MSK109HRH, KRH, EDURH, VRH..... -55°C to +125°C  
 MSK109RH, PRH..... -40°C to +85°C

Tst Storage Temperature Range.....-65°C to +150°C  
 TLD Lead Temperature Range  
 (10 Seconds).....300°C  
 Tj Junction Temperature..... +150°C  
 ESD Rating ..... 2

## ELECTRICAL SPECIFICATIONS

Parameter	Test Conditions ① ⑦	Group A Subgroup	MSK109HRH/KRH/EDURH/VRH			MSK109RH/PRH			Units
			Min.	Typ.	Max.	Min.	Typ.	Max.	
Reverse Breakdown Voltage		1	2.495	-	2.505	2.495	-	2.505	V
	Post Radiation	1	2.494	-	2.506	2.494	-	2.506	V
Reverse Breakdown Voltage Change with Current	400µA ≤ IR ≤ 10mA	1	-6	3.5	+6	-6	3.5	+6	mV
		2, 3	-10	-	10	-	-	-	mV
	Post Radiation	1	-12	-	+12	-12	-	+12	mV
Reverse Dynamic Impedance ②		1	-	-	0.6	-	-	0.6	Ω
		2, 3	-	-	1.0	-	-	-	Ω
	Post Radiation	1	-	-	1.4	-	-	1.4	Ω
Temperature Stability		2, 3	-15	10	+15	-	-	-	mV
Long-Term Stability ②	Ta = 25°C ±0.1°C, IR = mA	-	-	20	-	-	20	-	PPM/KHr
Thermal Resistance ②	Junction to Case @ 125°C	-	-	26	30	-	26	30	°C/W

### NOTES:

- ① Unless otherwise specified; IR=1mA, ADJ=OPEN.
- ② Guaranteed by design but not tested. Typical parameters are representative of actual device performance but are for reference only. Not applicable to post irradiation performance.
- ③ Industrial and Prototype grade devices shall be tested to subgroup 1 unless otherwise specified.
- ④ Military grade and EDU devices shall be 100% tested to subgroups 1,2 and 3.
- ⑤ Subgroup 1 TA = TC = +25°C  
 Subgroup 2 TA = TC = +125°C  
 Subgroup 3 TA = TC = -55°C
- ⑥ Continuous operation at or above absolute maximum ratings may adversely effect the device performance and/or life cycle.
- ⑦ Pre and Post irradiation limits at 25°C, to 100Krad TID, are identical unless otherwise specified. Post irradiation performance is guaranteed by design with a 2X radiation design margin.

**BREAKDOWN VOLTAGE**

The breakdown voltage of the MSK109RH can be optimized to meet the applications circuit requirement and/or adjust for the initial voltage tolerance. As shown in Figure 1, a 10K potentiometer is added in parallel with the V+ and V- of the voltage reference with the potentiometer adjust pin connected to ADJ of the voltage reference. The output voltage trim range for the circuit is approximately ±5%. Leave the adjust pin unconnected if the adjust feature is not used.

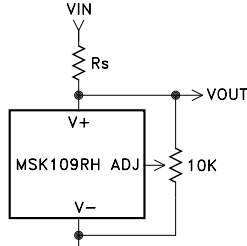

FIGURE 1

**PRECISION REFERENCE FOR LINEAR REGULATOR**

The MSK109RH provides increased initial accuracy and reduced drift due to temperature and irradiation to the output accuracy of the MSK5976RH, MSK5977RH and the MSK5953RH radiation hardened linear regulators. The MSK5977RH is used in the provided examples. Refer to the respective data sheets for more specific information on each device. Figure 2 shows the MSK109RH configured to set a precision current in a resistor divider network setting the final output voltage of the MSK5977RH. This configuration allows the output voltage of the MSK5977 to be adjusted between 0V and the maximum range of the MSK5977RH. The current in R1 is equal to the reference voltage divided by R1. The current in R2 is equal to the current in R1 plus the 10uA nominal set pin current. By setting the current in R1 to 1mA or greater the accuracy error of the set pin current is swamped out by the higher accuracy of the MSK109RH reference. To maintain high accuracy R1 and R2 tolerance should be 0.1% or better with low and/or matching TCR. This configuration swamps out initial accuracy error, temperature drift, drift due to irradiation, line regulation and load regulation error of the set pin current. The MSK109RH may be biased from Vin, nVcontrol or a separate source but it must be greater than Vout by 2.5Vh plus the drop across RS; VMIN=VOUT+2.5VREF+VRS. The minimum output load must sink the minimum load current from the MSK5977RH plus the current passing through the MSK109RH to maintain regulation. The source used to bias the reference must also supply the divider current set by the reference and the R1.

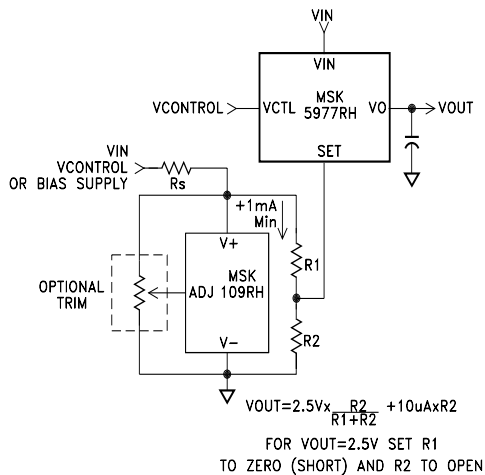

FIGURE 2

To maintain high accuracy R1 and R2 tolerance should be 0.1% or better with low and/or matching TCR

Figure 3 shows the MSK109RH configured with the MSK5977RH to provide the same accuracy improvement benefits as the circuit above but require less voltage overhead and it does not require the load to sink the divider current. This configuration is limited to an output operating range of 0V to 2.5V. For 2.5V output R1 would be zero ohms leaving the set pin of the regulator connected directly to the V+ terminal of the reference; R2 can also be omitted (left open) in the 2.5V configuration. Select Rs or a current source to maintain between one and ten milliamps in the reference and supply the resistor divider current under all operating conditions. The resistor divider current should be 1mA or greater to swamp out the effects of the set pin current except in the 2.5V (no divider) case. As above, R1 and R2 tolerance should be 0.1% or better tolerance with low and/or matching TCR for best accuracy.

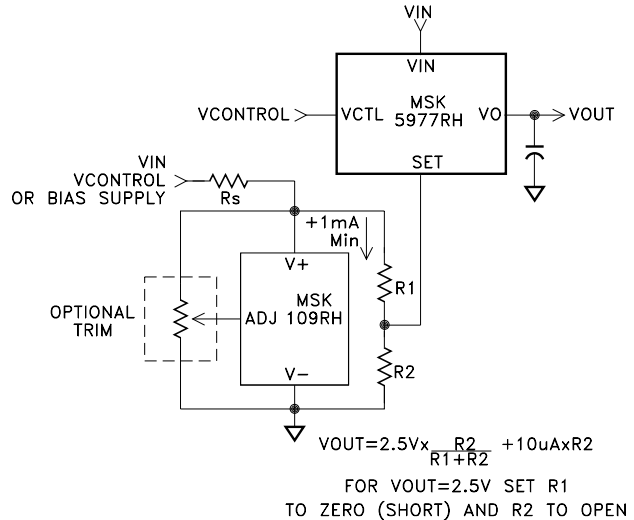

FIGURE 3

To maintain high accuracy R1 and R2 tolerance should be 0.1% or better with low and/or matching TCR

**TOTAL DOSE RADIATION TEST PERFORMANCE**

Radiation performance curves for TID testing have been generated for all radiation testing performed by Anaren, MSK Products. These curves show performance trends throughout the TID test process and are located in the MSK109RH radiation test report. The complete radiation test report is available in the RAD HARD PRODUCTS section on the Anaren website for microelectronics products.

**ADDITIONAL APPLICATION INFORMATION**

For additional applications information, please reference Linear Technology Corporation's® LT1009 and RH1009 data sheets.

# TYPICAL PERFORMANCE CURVES

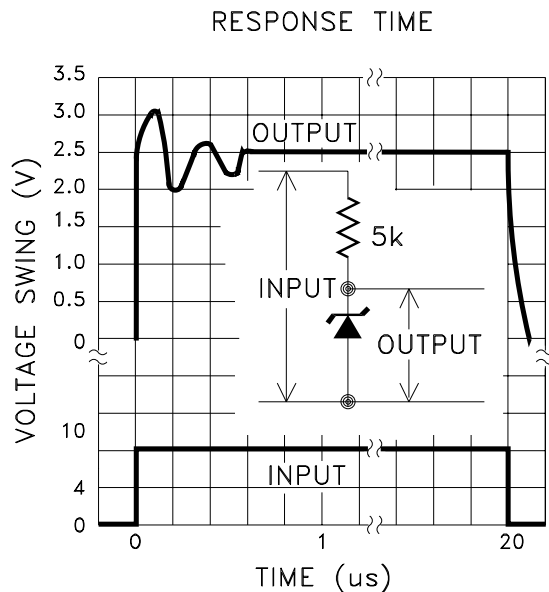
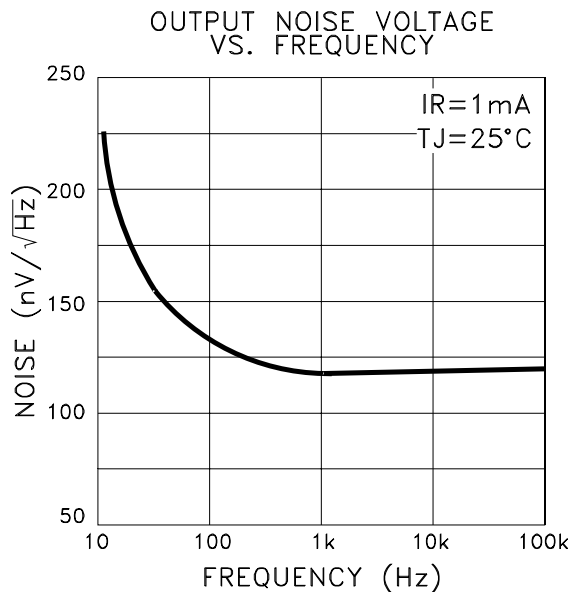
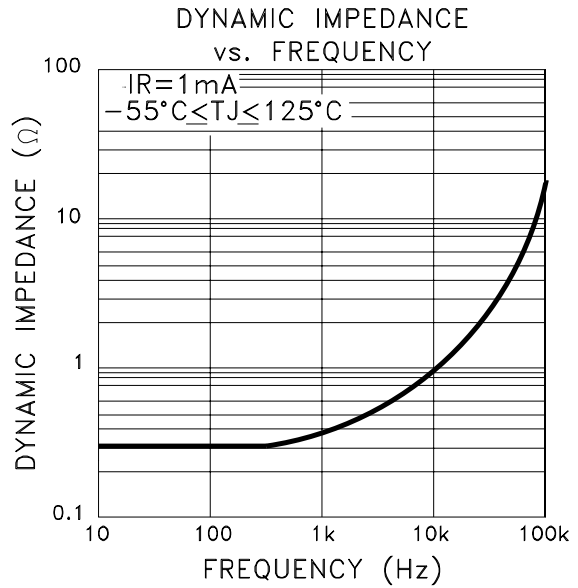
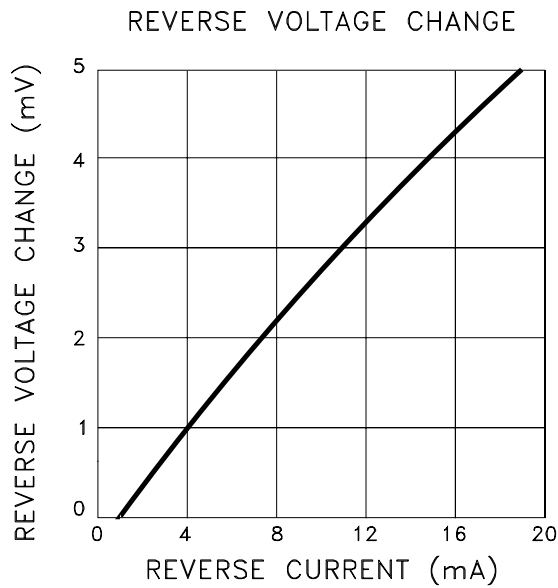
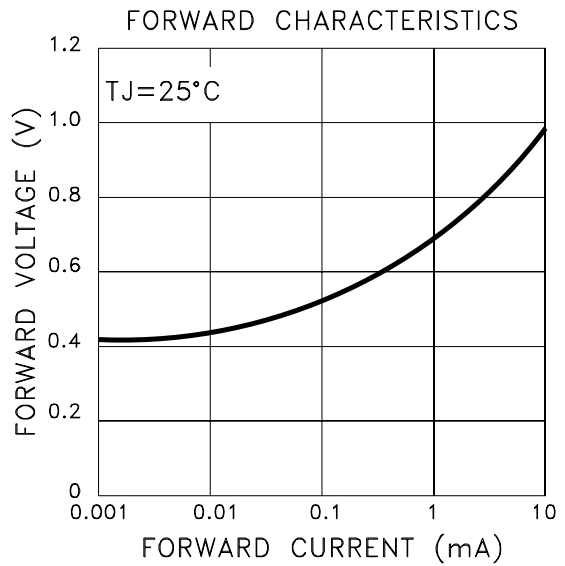
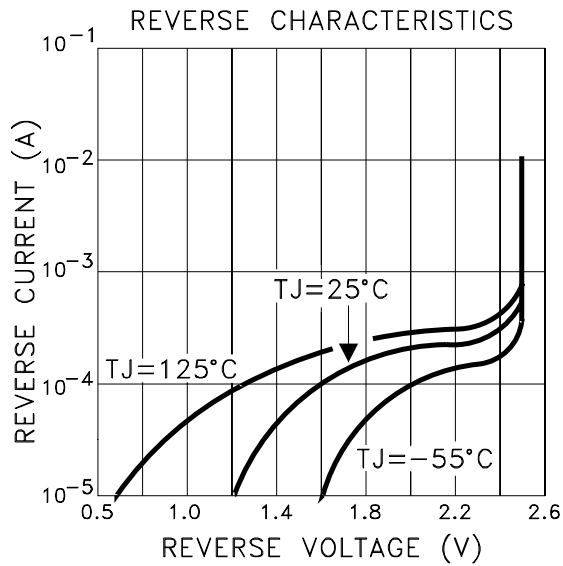

## MECHANICAL SPECIFICATIONS

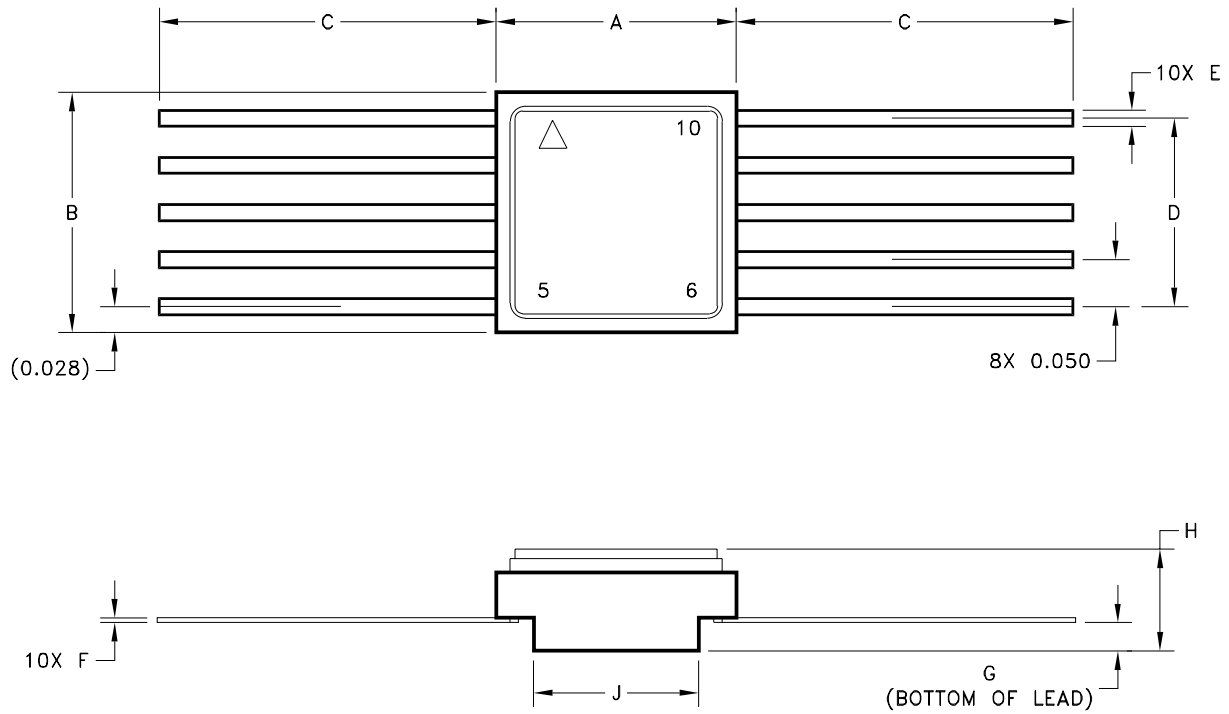

REF	MIN	MAX
A	0.245	0.265
B	0.245	0.265
C	0.250	—
D	0.195	0.205
E	0.015	0.019
F	0.004	0.006
G	0.026	—
H	—	0.115
J	0.170	0.180

ESD TRIANGLE INDICATES PIN 1  
WEIGHT=0.36 GRAMS TYPICAL

ALL DIMENSIONS ARE SPECIFIED IN INCHES

## ORDERING INFORMATION

MSK109 V RH

### LEAD CONFIGURATIONS

BLANK = STRAIGHT

### RADIATION HARDENED

### SCREENING

BLANK = INDUSTRIAL

V = MIL-PRF-38535 CLASS V; P = PROTOTYPE;

EDU = ENGINEERING DEVELOPMENT UNIT;

H = MIL-PRF-38534 CLASS H; K = MIL-PRF-38534 CLASS K

### GENERAL PART NUMBER

The above example is a Class V Voltage Reference with straight leads.

## MECHANICAL SPECIFICATIONS

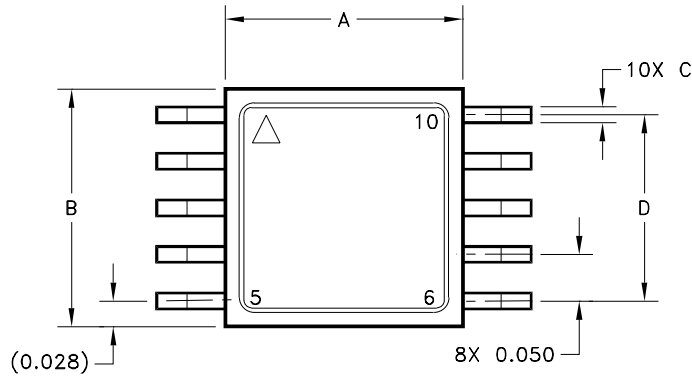

REF	MIN	MAX
A	0.245	0.265
B	0.245	0.265
C	0.015	0.019
D	0.195	0.205
E		0.115
F	0.0275	0.0475
G	0.390	0.415
H	0.004	0.006
J	-0.005	0.005
K	0.170	0.180

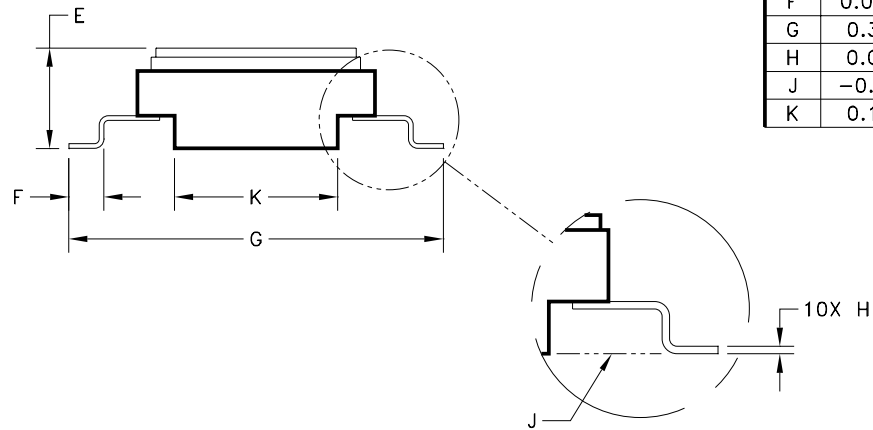

**NOTE: LEADS SHALL BE COPLANAR (J) WITH THE PACKAGE**

ESD TRIANGLE INDICATES PIN 1  
WEIGHT=0.3 GRAMS TYPICAL

ALL DIMENSIONS ARE SPECIFIED IN INCHES

## ORDERING INFORMATION

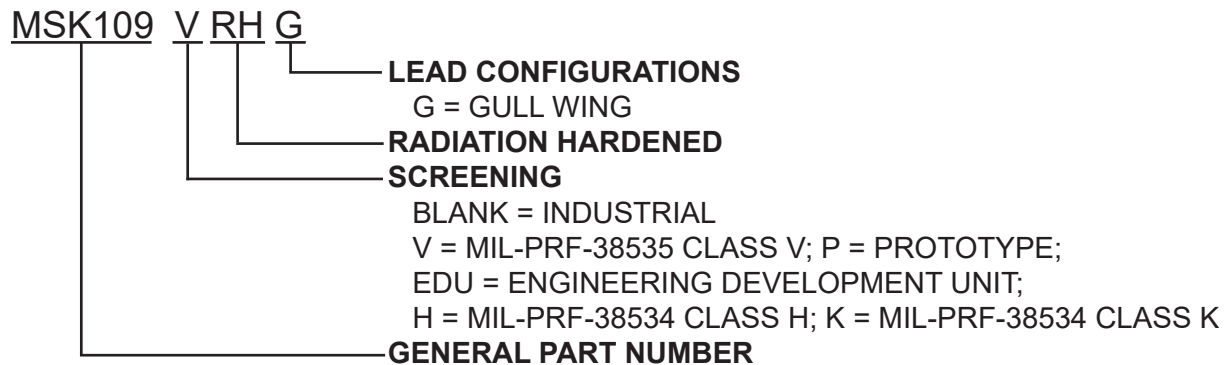

The above example is a Class V Voltage Reference with gull wing lead form.

## REVISION HISTORY

REV	STATUS	DATE	DESCRIPTION
F	Released	12/14	Add lid-isolated to pin out info, ESD rating, DLA SMD and update format.
G	Released	04/15	Remove reference to DLA SMD
H	Released	09/17	Update parameters to better correlate to manufacturer's pre and post RAD specs.
J	Released	11/18	Update mechanical specifications
K	Released	1/19	Remove MIL-PRF-38535 Certified Facility

ANAREN, MSK Products  
[www.anaren.com/msk](http://www.anaren.com/msk)

---

The information contained herein is believed to be accurate at the time of printing. Anaren, MSK products reserves the right to make changes to its products or specifications without notice, however and assumes no liability for the use of its products.  
Please visit our website for the most recent revision of this datasheet.